

PANAGET

— Wood Flooring & Wall Panelling —



TECHNICAL LIST 2023



P. 13 French oak Zenitude Bois flotté, Diva 139

Single plank



P. 21 French oak Tradition Sable, Alto 139x1210



P. 22



Patterns

P. 26 French oak Classic Satin, Carmen n°2



High Traffic



P. 27 French oak Authentic Café crème High Traffic, Diva 139

Laying systems



Unifit Click :
Glue-free floating installation



2BeClick :
Glue-free floating installation



Floating glued installation



Glue down installation

Finishes



Matt lacquer
More info page 45



Satin lacquer
More info page 45



Oil
More info page 45



Matt lacquer High Traffic
More info page 27

Compatibility with underfloor heating



Compatible with low-temperature
underfloor heating
More info page 40



Compatible with reversible underfloor
heating and cooling systems
More info page 41

TABLE OF CONTENTS



P. 23 French oak Mix Bois flotté,
Single plank 139



Two strip

P. 23 French oak Tradition Satin,
Orféo 139



Solids

P. 28 French oak Zenitude Miel, Sonate 140



Aged flooring

P. 30 French oak Zenitude-Origine
Tufeau, Diva 184



Wall panelling

P. 37 French oak Gris cabane
CBM 141

P. 6 GLOSSARY

- 6-7 Flooring dimensions
- 8 Our wood grading
- 9 Bevels & Species
- 10 Finishes & Types of finishes

P. 12 SINGLEPLANK

/ RANDOM LENGTHS & FIXED PACKING:

- 12 Diva 90 click / 12 mm
- 13 Diva 139 click / 12 mm
- 14 Diva 139 click / 14 mm
- 15 Diva 139 T&G / 14 mm
- 16 Diva 184 click / 12 mm
- 17 Diva 184 click / 14 mm
- 18 Diva 184 T&G / 14 mm
- 19 Diva 184 T&G / 15 mm
- 19 Diva 223 T&G / 15 mm

/ FINGER JOINTED LENGTHS:

- 20 Alto 139 & 184x2010 Unift click / 12 mm
- 21 Alto 139x1210 Unift click / 12 mm

/ FIXED LENGTHS:

- 22 Single plank 139 Unift click / 12 mm

P. 23 ENGINEERED TWO-STRIP

- 23 Orféo 139 click / 14 mm

P. 24 PATTERNS

- 24 Chevron 90 & 139 / 14 mm
- 25 Herringbone 90 / 12 mm & 139 / 14 and 13 mm
- 26 Carmen

P. 27 HIGH TRAFFIC

- 27 Range of High Traffic wood flooring

P. 28 SOLIDS

- 28 Sonate 90 & 140 / 14 mm
- 29 Ulysse / 12 mm

P. 30 AGED FLOORING

- 30 Zenitude-Origine
- 30 Zenitude-Salvagio
- 30 Shabi

P. 31 MULTI-WIDTHS

- 31 Our combinations

P. 32 ACCESSORIES

- 32 Laying accessories
- 33 Finishing accessories
- 35 Maintenance accessories

P. 36 WALL PANELLING

- 36 Technical scheme
- 37 Wall panelling range

P. 38 ADVICE & TOOLS

- 38 Classes of use
- 39 Practical advice
- 40-41 Underfloor heating and cooling system
- 42 Fitting instructions
- 43 Discover the Panaget range
- 44-45 Care and cleaning
- 46 Expoz' by Panaget
- 48 & 49 Guarantee and general terms of sale

P. 50 PANAGET COLOR CHART

The 23 Panaget finishes



Technical specifications and performance statements for all products are available at:

www.panaget.com



Except Teak, Ulysse 90.



All French oak and Beech products except Sonate 90, Sonate 140 and accessories.



For design, creation and manufacture, choose the French quality.

Flooring with a certified origin. 100% French oak offers superior mechanical properties, high density, incredible industrial adaptability, and international recognition... As such, there is no better choice. Genuine French oak from sustainably managed forests for nearly two centuries.

Panaget has been PEFC certified since 2002. Only products identified as such on this document are certified PEFC 100%. Certificate no. QUAL/18-1112. This is also mentioned on each product sheet which can be available and downloaded from our website our website www.panaget.com.

Our quality department sets up quality processes at each production steps to never settle for the second best.

At Panaget, our flooring range and wall panelling products comply with all EU health and safety directives.

Our wood flooring or wall panelling will be a unique, one-off piece made with Panaget's signature care and attention to detail. This guarantee is our commitment to fully satisfy you. For more info, see page 48.



For your project, Choose Panaget Wood Flooring & Wall Panelling



LINEN
French oak | Mixed Classic/Authentic | Herringbone 90 (page 26)

DESIGN

100% DESIGN



100% ECO-FRIENDLY



100% FRENCH OAK

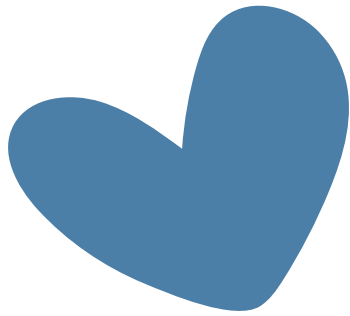

of range

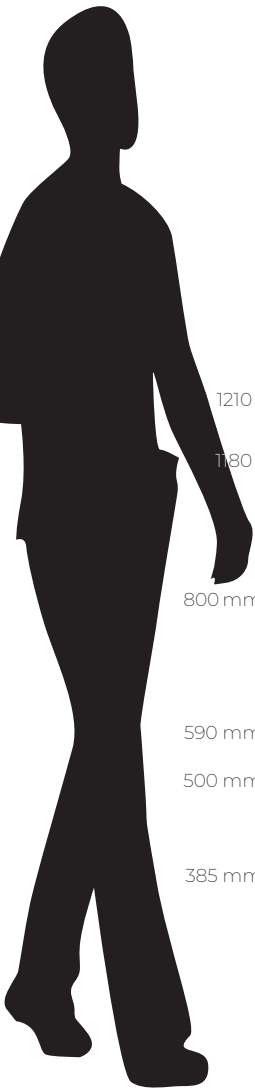

ENGINEERED WOOD FLOORING

ENGINEERED WOOD FLOORING

RANDOM LENGTHS & FIXED PACKING

FINGER JOINTED

Width (mm)	Diva 90	Diva 139		Diva 184	Diva 223	Alto 139	Alto 184	Alto 139
Length (mm)	385 to 1180	495 to 1992	500 to 2000	495 to 1992	500 to 2000	2010	2010	1210
	Page 12	Pages 13 to 15		Pages 16 to 19		Page 20	Page 20	Page 21



Flooring Dimensions

BY PANAGET

Whether you are opting for engineered flooring or solid wood flooring, single plank or two-strip, make sure that you carefully measure the size of your room, the decor, the style that you want to achieve and then make your choice!
The graphic below summarizes all the possible options!

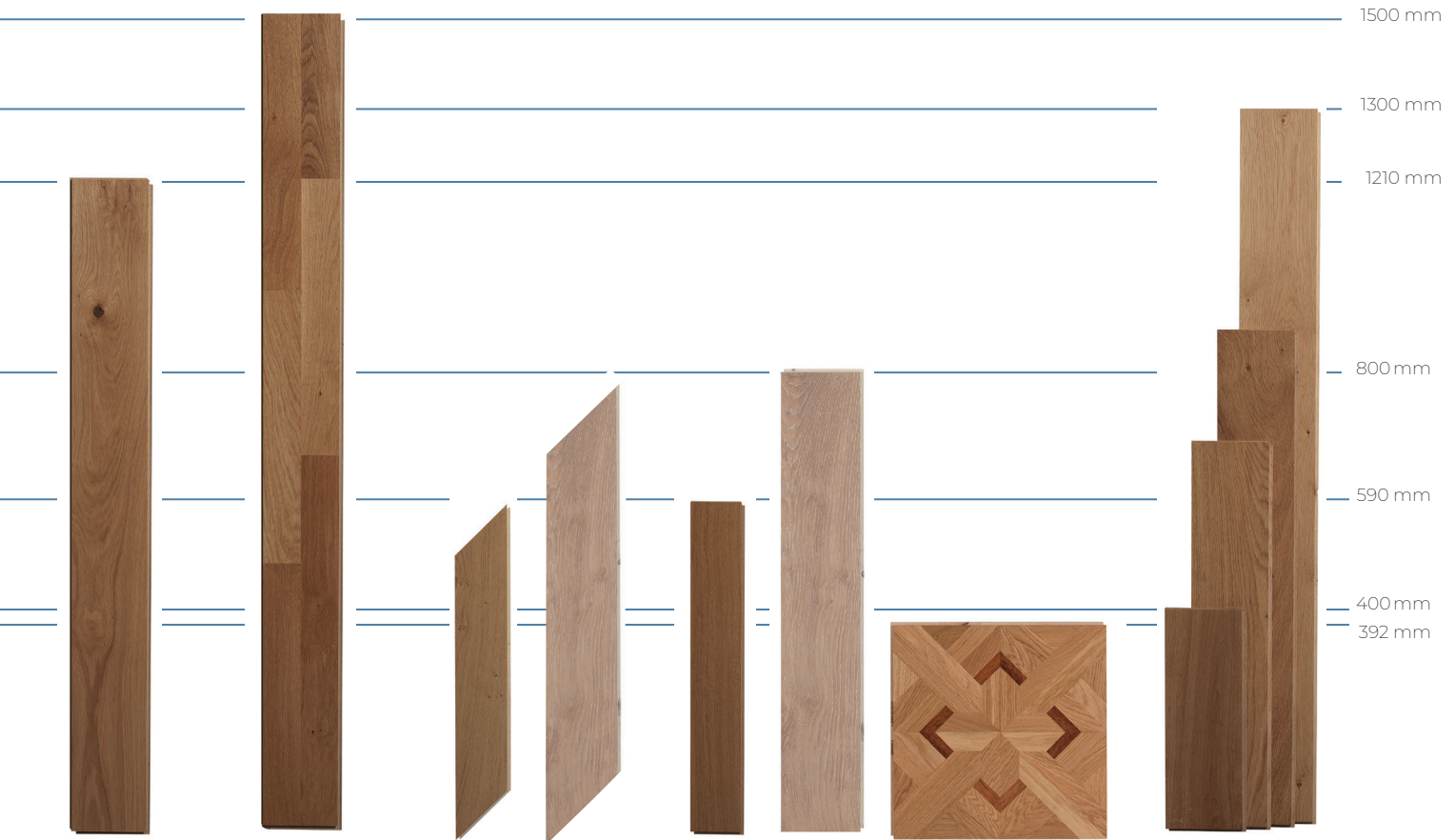

ENGINEERED WOOD FLOORING						SOLIDS WITH RANDOM LENGTHS		
FIXED LENGTHS		PATTERNS						
Monolame 139	Orféo 139	Chevron 90	139	Herringbone 90	139	Carmen 392	Sonate 90 or 140	Width
1210	1500	589	789	590	800	392	400 to 1300	Length
Page 22	Page 23	Page 24		Page 25		Page 26	Pages 28 to 29	

Glossary
Single plank to random lengths
Single plank Finger jointed lengths
Fixed length
Patterns
High Traffic
Solids with random lengths
Aged flooring and multi-widths
Accessories
Wall Panelling
Advice & Tools

Our Wood Grading

IN FRENCH OAK

Wood is natural and has multiple **peculiarities** that is why we organize it by appearance. All Panaget wood flooring planks are carefully selected according to the specific criteria of each choice.

Find here our wood in its raw state.



To find out more about our wood grades, scan this QR code.

The Essentials



CLASSIC (SELECT)

Light and dark wood, black knots, medular rays, discolouration.



AUTHENTIC (MIDDLE GRADE)

Light and dark wood, black knots, filled knots, partially opened knots, discolouration, black marks, cracks. The size of the knots is proportional to the width of the planks.



ZENITUDE (RUSTIC)

Light and dark wood, black knots, filled knots, opened knots, discolouration, cracks, splits, sapwood. Grade with all the peculiarities of the wood without limitation. The size of the knots is proportional to the width of the planks. Zenitude is available in two other surface aspects:
 - **Origine**, characterized by aged bevels &
 - **Salvagio**, characterized by structured, sometimes irregular facings.

The indispensable



MIX

A lightly sorted grade, dedicated to stock ranges, representing a mix of our "Essentials" grades. This combination ensures a warm and lively look.

& also available



TRADITION

Light and dark wood, black knots, filled knots, partially opened knots, discolouration, black marks, filled cracks, sapwood.



INTENSO

Light and dark wood, black knots, filled knots, partially opened knots, all discolouration, cracks, sapwood without limitation, bluish sapwood. Grade with all the peculiarities of the wood without limitation.

In brief

	Diva 	Sonate	Herringbone	Chevron	Carmen	Orféo	Alto	Single plank
Classic	●	●	●	●	●	●		
Authentic	●	●	●	●				
Zenitude	●	●	●	●			●	
Mix							●	●
Tradition						●	●	
Intenso	●							



Bevels

BY PANAGET

The **bevel** is the border and edge of the plank, two planks cut together will leave a bevel in between. Cut at 45 degrees to the main face. But that is not all: bevels are also decorative in order to highlight the width of the plank in your room.

Choose the bevels you like across all our ranges.



Available for:
Diva 90-139 & 184, Chevron, Herringbone and Sonate 90 & 140



Available for:
Alto, Monolame and Diva 223
Diva 139 & 184 (1 ref.)



Available for:
Diva 139 & 184, Herringbone 139 and Sonate 140



Available for:
Carmen, Orféo and Ulysse
Diva 139 (1 ref.)

Species

BY PANAGET

Whether you choose a light or dark wood, the colour of your new wood floors will evolve over time as a result of exposure to UV light. You can see this natural oxydation by moving a rug or a piece of furniture covering the floor few weeks after it has been laid. The lighter area will take on the same colour as the rest of the wood floors within a few weeks. The uncovered part of the floor will come back to its original colour within a few weeks.



Origin: France
Light brown wood
Light and dark wood - knots
Available in all formats except Ulysse



Origin: France
Flamed reed wood
Light and dark wood - knots - all peculiarities accepted
Available as: Diva 139 click, 14 mm ; Herringbone 139, 14 mm

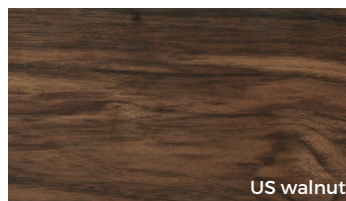

Origin: North America
Grey brown to dark brown wood
Light and dark wood - knots - sapwood
Available as: Diva 139 T&G, 14 mm ; Herringbone 139 T&G, 13 mm
- wood species sensitive to UV-light -



Origin: Indonesia
Yellowish brown to dark brown
Variation in colour from one plank to the next - quarter - knots - discolouration allowed
Available as: Ulysse 90, 12 mm



Finishes

BY PANAGET

Lacquer* or Oil? The choice is yours! Our finishes have all one thing in common: they bring out the natural character of the wood. Lacquered or oiled, our finishes always respect the wood beauty. There are three types of finish: Extra matt varnish, Satin lacquer, Oil.

OIL



Panaget oiled-floors are professionally UV-cured during the production process. This finish brings out the natural beauty of the wood and provides unique stains. When cared properly it will last for ever.

After installation, apply a thin coat of Panaget natural maintenance oil.

Find our maintenance accessories page 35 and the complete Panaget range on the colour chart on pages 50 and 51.

OILED FINISHES IN FRENCH OAK

TIMELESS NATURAL HUES



BOIS NATUREL OIL
Brushed, matt oiled with unfinished aspect

NATURAL OIL
Brushed, matt natural oiled

AMANDE
Natural brushed, slightly ceruse oiled

SABLE
Natural brushed, white patina matt oiled

DAYLIGHT WHITES



SHABI CHAUX
Brushed, aged-finish white matt oiled

WHITE OIL
Brushed, white matt oiled

TUFEAU
Brushed, chalk-tone matt oiled

SUBTLE GREYS



RAFIA
Brushed, raffia-tone matt oiled

GREY OIL
Brushed, grey matt oiled

FLANELLE
Brushed, grey-brown-tone matt oiled

ELEGANT BROWNS

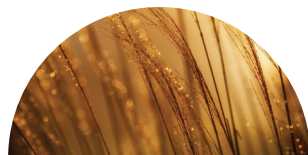

CUIR
Brushed, old leather-tone matt oiled

TOURBE
Brushed, dark brown-tone matt oiled

OILED FINISHES IN FLAMED BEECH



NATURAL OIL
Unbrushed, matt natural oiled

CUIVRE
Unbrushed, brown copper tone matt oiled



Is your customer undecided about the choice of the colour of their wood floor?
Introduce them to our simulator
Imagine by Panaget!

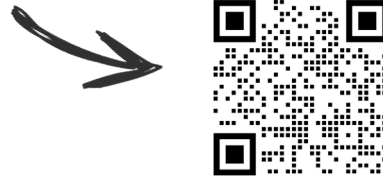











EXTRA-MAT LACQUER 

SATIN LACQUER 

For our **lacquered wood floors**, 5 to 7 finishing coats are applied. Our wood floors are covered by five to seven coats of Ecostrong lacquer in our factory. This factory-applied acrylic lacquer, UV-cured, contains corundum particles giving an ultra-hard surface. Our high-quality state-of-the-art lacquered ensure **effective protection** against all wood floor's traditional enemies: abrasion, scratches, stains, etc. It is available in **satin** and **matt versions**. Both esthetic and resistant, lacquering is by far the most widespread finish and above all the easiest to maintain.

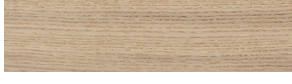
 For **specifics public areas**, use a more resistant lacquer called **High Traffic** (more information on page 27).

LACQUERED FINISHES IN FRENCH OAK

Timeless natural hues		BOIS FLOTTÉ* Brushed, matt lacquered with unfinish aspect		SATIN Unbrushed, satin lacquered	
		TOPAZE* Brushed, matt lacquered			OPALE Brushed, satin lacquered
		MIEL* Brushed, natural matt lacquered			
Daylight whites		SAPHIR Brushed, white matt lacquered			
		LINEN Brushed, light white matt lacquered			
Subtle greys		CAFÉ CRÈME* Brushed, coffee latte tone matt lacquered			
Elegant browns		ARGILE Brushed, clay-tone matt lacquered		FAUVE Brushed, brown satin lacquered	
		HABANO Brushed, tobacco-leaf-tone matt lacquered			

LACQUERED FINISHES IN FLAMED BEECH

	BOIS FLOTTÉ Unbrushed, matt lacquered with unfinish aspect		SATIN Unbrushed, satin lacquered
---	--	--	--

*Also available in High Traffic lacquer.



DIVA 90 / 12 MM CLICK

Engineered single plank to **random lengths**, HDF core - 4 bevels
Made under the patent EN 13489



Species	Grade	Finishes	Lacquer	Oil	Bevels type	Class of use	Item number	Photo on
FRENCH OAK	Classic (<i>select</i>)	Linen					1020641	panaget.com
	Classic (<i>select</i>)	Satin			4 bevels	23	1005768	panaget.com
	Classic (<i>select</i>)	Topaze					1005769	panaget.com
	Authentic (<i>middle grade</i>)	Cuir			4 bevels	23	1014174	panaget.com
	Zenitude (<i>rustic</i>)	Bois flotté				4 bevels	23	1015663

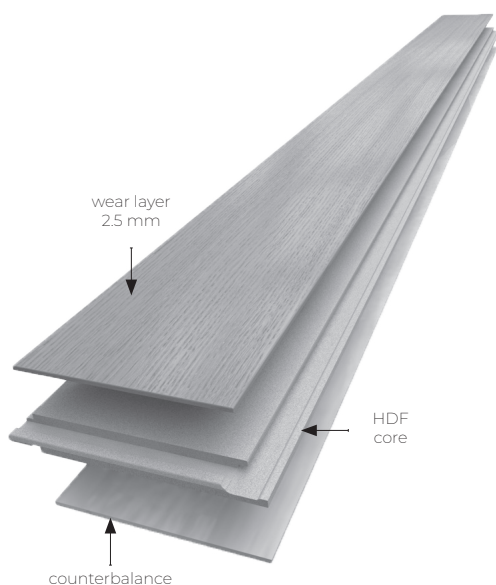

CHARACTERISTICS

Lengths	385 to 1180 mm
more details on pages 6 and 7	
Width	90 mm
Thickness	12 mm
Wear layer	2.5 mm
Core	HDF



- floating installation using plastic DPM + Isol 20
- or fully glue down using our special presto PM glue



fully glue down using our special presto PM glue

PACKING

Weight / sqm	9.9 kg
Sqm / pack	1.47
Pack / pallet	44
Sqm / pallet	64.68





DIVA 139 / 12 MM CLICK

Engineered wide single plank to **random lengths**, HDF core - 4 bevels
Made under the patent EN 13489



Species	Grade	Finishes	Lacquer	Oil	Bevels type	Class of use	Item number	Photo on the catalogue 2022-23 or on
FRENCH OAK	Classic (select)	Bois flotté					1005774	panaget.com
	Classic (select)	Opale			4 bevels	23	1005776	page 18
	Classic (select)	Satin					1005777	panaget.com
	Classic (select)	Topaze					1005764	panaget.com
	Authentic (middle grade)	Bois flotté					1017897	panaget.com
	Authentic (middle grade)	Cuir					1014176	page 60
	Authentic (middle grade)	Linen			4 bevels	23	1000299	page 36
	Authentic (middle grade)	Miel					1019167	panaget.com
	Authentic (middle grade)	Topaze					1000300	panaget.com
	Zenitude (rustic)	Amande*					1021339	panaget.com
	Zenitude (rustic)	Bois flotté					1007643	page 13
	Zenitude (rustic)	Café crème					1019168	pages 46-47
	Zenitude (rustic)	Habano					1007647	page 57
	Zenitude (rustic)	Bois naturel oil			4 bevels	23	1021212	panaget.com
	Zenitude (rustic)	Linen					1007649	panaget.com
	Zenitude (rustic)	Natural oil					1007645	panaget.com
	Zenitude (rustic)	Sable					1017898	panaget.com
	Zenitude (rustic)	Tufeau					1007639	panaget.com
	Zenitude (rustic)	White oil					1007644	pages 34-35
	Intenso	Bois flotté					1017017	pages 14-15
Intenso	Cuir			4 bevels	23	1015661	panaget.com	
Intenso	Tufeau					1015662	panaget.com	

*Amande is a finish that reveals the peculiarities of the wood. We recommend that you mix the packages well when laying.

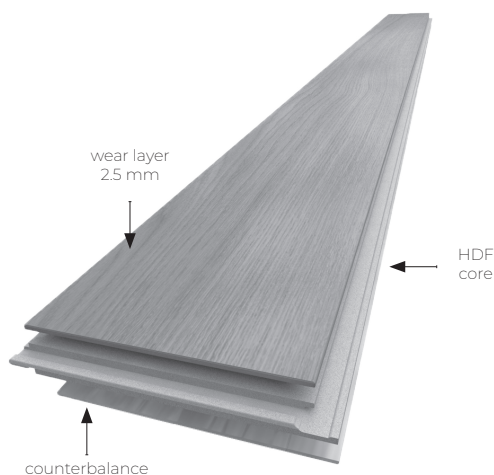

80% of the surface of the package is made with planks greater than 1 m.

CHARACTERISTICS

Lengths more details on pages 6 and 7	495 to 1992 mm
Width	139 mm
Thickness	12 mm
Wear layer	2.5 mm
Core	HDF

PACKING

Weight / sqm	9.9 kg
Sqm / pack	1.38
Pack / pallet	65
Sqm / pallet	89.7



- floating installation using plastic DPM + Isol 20
- or fully glue down using our special presto PM glue



fully glue down using our special presto PM glue





DIVA 139 / 14 MM CLICK

Engineered wide single plank to **random lengths**, HDF core - 4 bevels
Made under the patent EN 13489



Species	Grade	Finishes	Lacquer	Oil	Bevels type	Class of use	Item number	Photo on the catalogue 2022-23 or on	
FRENCH OAK	Classic (<i>select</i>)	Bois flotté					1019701	panaget.com	
	Classic (<i>select</i>)	Linen					1019702	panaget.com	
	Classic (<i>select</i>)	Opale			4 bevels	31	1006162	page 18	
	Classic (<i>select</i>)	Satin					1000553	panaget.com	
	Classic (<i>select</i>)	Topaze					1000554	panaget.com	
	Authentic (<i>middle grade</i>)	Bois flotté					1019700	panaget.com	
	Authentic (<i>middle grade</i>)	Cuir					1019704	page 60	
	Authentic (<i>middle grade</i>)	Miel			4 bevels	31	1019705	panaget.com	
	Authentic (<i>middle grade</i>)	Saphir					1019706	page 33	
	Authentic (<i>middle grade</i>)	Topaze					1019703	panaget.com	
	Authentic (<i>middle grade</i>)	Tufeau					1019707	panaget.com	
	Authentic (<i>middle grade</i>)	Bois flotté				4 bevels	31	1021037	panaget.com
	Authentic (<i>middle grade</i>)	Café crème				4 bevels	31	1021038	panaget.com
	Authentic (<i>middle grade</i>)	Topaze				4 bevels	31	1021039	panaget.com
	Zenitude (<i>rustic</i>)	Bois flotté					1019708	page 13	
Zenitude (<i>rustic</i>)	Fauve			4 bevels	31	1019709	page 61		
Zenitude (<i>rustic</i>)	Natural oil					1019710	panaget.com		
FLAMED BEECH*		Bois flotté					1019712	page 66	
		Cuivre					1019714	pages 64-65	
		Natural oil			4 bevels	31	1019713	page 67	
		Satin					1019711	page 68	

*Beech is very sensitive to UV-light causing colour variations over the years. It should therefore not be laid in front of large windows.

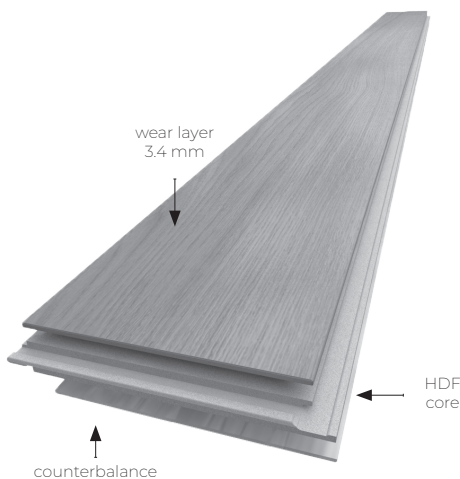

80% of the surface of the package is made with planks greater than 1 m.

CHARACTERISTICS

Lengths	495 to 1992 mm
more details on pages 6 and 7	
Width	139 mm
Thickness	14 mm
Wear layer	3.4 mm
Core	HDF

PACKING

Weight / sqm	11.6 kg
Sqm / pack	1.38
Pack / pallet	55
Sqm / pallet	75.90



- floating installation using plastic DPM + Isol 20
- or fully glue down using our special presto PM glue
For Flamed Beech, fully glue down only using our special presto PM glue.





DIVA 139 / 14 MM TONGUE & GROOVE

Engineered wide single plank to **random lengths**, plywood core
Made under the patent EN 13489



Species	Grade - Surface aspects	Finishes	Lacquer	Oil	Bevels type	Class of use	Item number	Photo on the catalogue 2022-23 or on
FRENCH OAK	Classic (<i>select</i>)	Bois flotté					1014261	panaget.com
	Classic (<i>select</i>)	Linen			4 bevels	31	1019715	panaget.com
	Classic (<i>select</i>)	Opale					1019716	page 18
	Classic (<i>select</i>)	Topaze					1019717	panaget.com
	Classic (<i>select</i>)	Satin			square edged	31	1005748	panaget.com
	Authentic (<i>middle grade</i>)	Topaze			4 bevels	31	1000297	panaget.com
	Zenitude - Origine	Cuir					1006522	pages 58-59
	Zenitude - Origine	Sable			2 aged bevels	31	1016633	panaget.com
	Zenitude - Origine	Tufeau					1006521	panaget.com
	Zenitude - Salvagio	Grey oil			2 bevels and sawing marks	31	1014171	page 51
Zenitude - Salvagio	Natural oil					1014172	page 25	
US WALNUT*	Mat				4 bevels	22	1021340	panaget.com
	Satin				4 bevels	22	1019718	page 70

*US walnut is very sensitive to UV-light causing colour variations over the years. It should therefore not be laid in front of large windows.

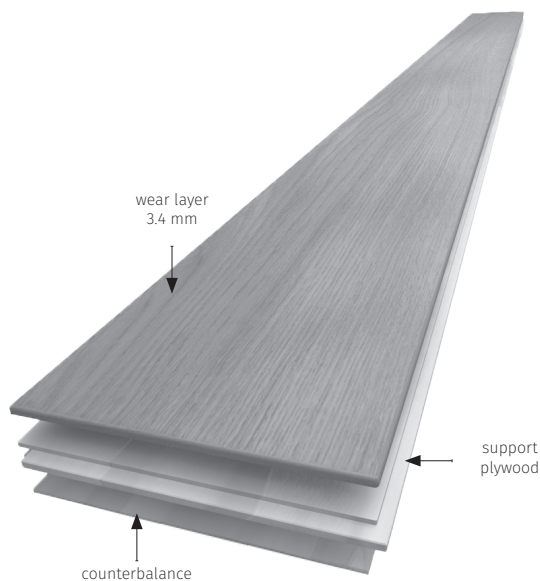

80% of the surface of the package
is made with planks greater than 1 m.

CHARACTERISTICS

Lengths more details on pages 6 and 7	500 to 2000 mm
Width	139 mm
Thickness	14 mm
Wear layer	3.4 mm
Core	plywood

PACKING

Weight / sqm	7.4 kg
sqm / pack	1.39
Pack / pallet	55
sqm / pallet	76.45



- floating installation
gluing T&G and using
plastic DPM + Isol 20
- or fully glue down using
our special presto PM glue





DIVA 184 / 12 MM CLICK

Engineered wide single plank to **random lengths**, HDF core - 4 bevels
Made under the patent EN 13489



Species	Grade	Finishes	Lacquer	Oil	Bevels type	Class of use	Item number	Photo on the catalogue 2022-23 or on
FRENCH OAK	Classic (<i>select</i>)	Bois flotté			4 bevels	23	1019817	page 12
	Authentic (<i>middle grade</i>)	Bois flotté					1000059	pages 10-11
	Authentic (<i>middle grade</i>)	Cuir			4 bevels	23	1014179	panaget.com
	Authentic (<i>middle grade</i>)	Bois naturel oil					1021213	panaget.com
	Authentic (<i>middle grade</i>)	Opale					1000060	page 19
	Authentic (<i>middle grade</i>)	Topaze					1000061	panaget.com
	Zenitude (<i>rustic</i>)	Bois flotté					1016424	panaget.com
	Zenitude (<i>rustic</i>)	Linen					1007320	panaget.com
	Zenitude (<i>rustic</i>)	Rafia			4 bevels	23	1007318	page 50
	Zenitude (<i>rustic</i>)	Sable					1017917	page 30
Zenitude (<i>rustic</i>)	Tufeau					1007319	page 40	

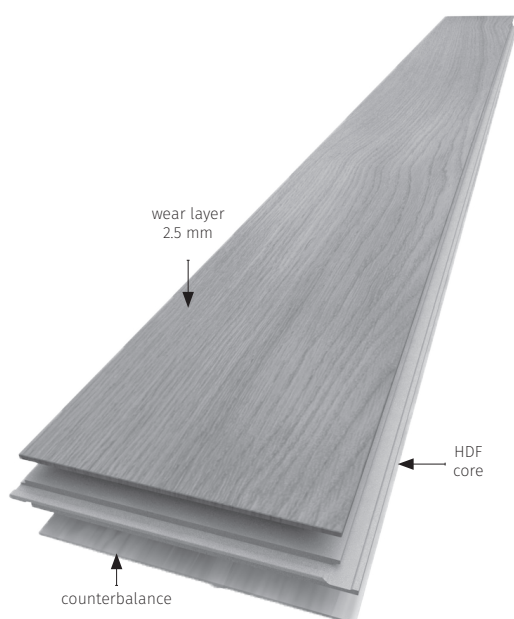

80% of the surface of the package is made with planks greater than 1 m.

CHARACTERISTICS

Lengths more details on pages 6 and 7	495 to 1992 mm
Width	184 mm
Thickness	12 mm
Wear layer	2.5 mm
Core	HDF

PACKING

Weight / sqm	9.9 kg
Sqm / pack	2.20
Pack / pallet	40
Sqm / pallet	88



- floating installation using plastic DPM + Isol 20
- fully glue down using our special presto PM glue



fully glue down using our special presto PM glue





DIVA 184 / 14 MM CLICK

Engineered wide single plank to **random lengths**, HDF core - 4 bevels
Made under the patent EN 13489



Single plank to
random lengths

Species	Grade	Finishes	Lacquer	Oil	Bevels type	Class of use	Item number	Photo on the catalogue 2022-23 or on
FRENCH OAK	Authentic (middle grade)	Bois flotté			4 bevels	31	1016640	pages 10-11
	Authentic (middle grade)	Topaze					1000065	panaget.com
	Zenitude (rustic)	Bois flotté			4 bevels	31	1021048	panaget.com
	Zenitude (rustic)	Miel					1021061	panaget.com
	Intenso	Bois flotté			4 bevels	31	1019818	panaget.com
	Intenso	Cuir					1020642	panaget.com

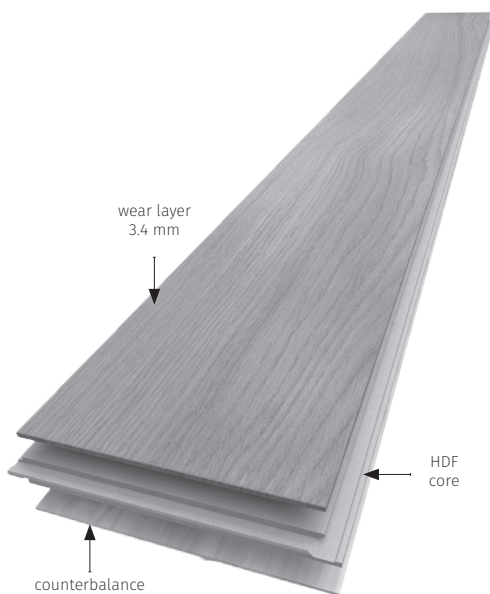

80% of the surface of the package is made with planks greater than 1 m.

CHARACTERISTICS

Lengths	495 to 1992 mm
more details on pages 6 and 7	
Width	184 mm
Thickness	14 mm
Wear layer	3.4 mm
Core	HDF

PACKING

Weight / sqm	11.6 kg
Sqm / pack	1.83
Pack / pallet	40
Sqm / pallet	73.20



- floating installation using plastic DPM + Isol 20
- or fully glue down using our special presto PM glue





DIVA 184 / 14 MM TONGUE & GROOVE

Engineered wide single plank to **random lengths**, plywood core
Made under the patent EN 13489



Species	Grade - Surface aspects	Finishes	Lacquer	Oil	Bevels type	Class of use	Item number	Photo on the catalogue 2022-23 or on
FRENCH OAK	Classic (<i>select</i>)	Bois flotté					1006159	page 12
	Classic (<i>select</i>)	Satin			4 bevels	31	1006161	page 16
	Classic (<i>select</i>)	Topaze					1006158	page 20
	Authentic (<i>middle grade</i>)	Bois flotté					1016634	pages 10-11
	Authentic (<i>middle grade</i>)	Cuir					1014166	panaget.com
	Authentic (<i>middle grade</i>)	Miel			4 bevels	31	1019170	pages 26-27
	Authentic (<i>middle grade</i>)	Saphir					1000069	panaget.com
	Authentic (<i>middle grade</i>)	Topaze					1000070	panaget.com
	Zenitude (<i>rustic</i>)	Amande*			4 bevels	31	1021217	panaget.com
	Zenitude (<i>rustic</i>)	Argile#			2 bevels	31	1016189	page 56
	Zenitude (<i>rustic</i>)	Bois flotté					1007330	panaget.com
	Zenitude (<i>rustic</i>)	Café crème			4 bevels	31	1019171	panaget.com
	Zenitude (<i>rustic</i>)	Fauve					1016472	panaget.com
	Zenitude (<i>rustic</i>)	Flanelle					1007324	page 54
	Zenitude (<i>rustic</i>)	Bois naturel oil			4 bevels	31	1021214	panaget.com
	Zenitude (<i>rustic</i>)	Grey oil					1007332	panaget.com
	Zenitude (<i>rustic</i>)	Linen					1007314	panaget.com
	Zenitude (<i>rustic</i>)	Natural oil					1007333	panaget.com
	Zenitude (<i>rustic</i>)	Rafia			4 bevels	31	1007325	page 50
	Zenitude (<i>rustic</i>)	Sable					1019280	page 30
	Zenitude (<i>rustic</i>)	Tourbe					1014165	page 62
	Zenitude (<i>rustic</i>)	Tufeau					1007326	page 40
	Zenitude-Origine	Cuir					1006550	panaget.com
	Zenitude-Origine	Sable			2 aged bevels	31	1016635	panaget.com
	Zenitude-Origine	Tourbe					1006552	panaget.com
	Zenitude-Origine	Tufeau					1006551	pages 38-39

*Amande is a finish that reveals the peculiarities of the wood. We recommend that you mix the packages well when laying.

#Argile is a tint that acts on wood's natural tannin properties to create an aged finish. In some cases, the shade may change slightly over time.

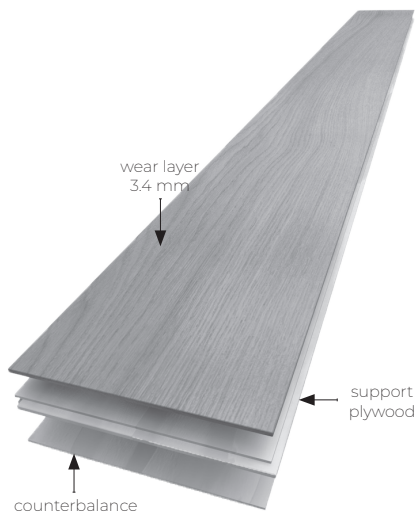

80% of the surface of the package is made with planks greater than 1 m.

CHARACTERISTICS

Lengths more details on pages 6 and 7	500 to 2000 mm
Width	184 mm
Thickness	14 mm
Wear layer	3.4 mm
Core	plywood

PACKING

Weight / sqm	7.4 kg
Sqm / pack	1.84
Pack / pallet	44
Sqm / pallet	80.96



- floating installation gluing T&G and using plastic DPM + Isol 20
- or fully glue down using our special presto PM glue





DIVA 184 ou 223 / 15 MM TONGUE & GROOVE

Engineered wide single plank to **random lengths**, plywood core
Made under the patent EN 13489



Single plank to
random lengths

Species	Grade	Finishes	Lacquer	Oil	Bevels type	Class of use	Item number	Photo on the catalogue 2022-23 or on
DIVA 184								
FRENCH OAK	Authentic (middle grade)	Cuir					1014182	panaget.com
	Authentic (middle grade)	Flanelle			4 bevels	33	1014183	panaget.com
	Authentic (middle grade)	Tufeau					1014185	page 37
	Authentic (middle grade)	Bois flotté					1021062	pages 10-11
	Authentic (middle grade)	Topaze			High Traffic Lacquer	4 bevels	33	1019081

Species	Grade	Finishes	Lacquer	Oil	Bevels type	Class of use	Item number	Photo on the catalogue 2022-23 or on
DIVA 223								
FRENCH OAK	Authentic (middle grade)	Argile					1017303	panaget.com
	Authentic (middle grade)	Bois flotté					1016985	panaget.com
	Authentic (middle grade)	Sable			2 bevels	33	1017302	panaget.com
	Authentic (middle grade)	Topaze					1016986	pages 22-23

4.5 mm extra-thick wear layer for commercial use (class 33).

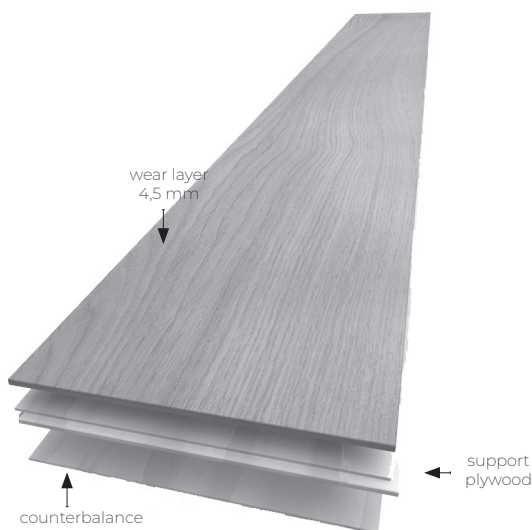

CHARACTERISTICS	184	223
Lengths more details on pages 6 and 7	500 to 2000 mm	2000 mm
Width	184 mm	223 mm
Thickness	15 mm	
Wear layer	4,5 mm	
Core	plywood	birch plywood
PACKING	184	223
Weight / sqm	7.9 kg	10.9 kg
Sqm / pack	1.84	1.78
Pack / pallet	44	39
Sqm / pallet	80.96	69.42



fully glue down using our special presto PM glue



184: 80% of the surface of the package is made with planks greater than 1 m.
223 : Minimum of three 2m long planks per pack. The 4th plank is either 700+1300 mm or 1000+1000 mm or 2000 mm.



ALTO 139 OR 184x2010 / 12 MM CLICK UNIFIT

Engineered twin & single stave plank, HDF core - 2 bevels
Made under the patent EN 13489



Species	Grade	Finishes	Lacquer	Bevels type	Class of use	Item number	Photo on
Alto 139x2010							
FRENCH OAK	Mix	Bois fotté		2 bevels	23	1017694	panaget.com
	Mix	Topaze				1017695	panaget.com

Species	Grade	Finishes	Lacquer	Bevels type	Class of use	Item number	Photo on
Alto 184x2010							
FRENCH OAK	Mix	Bois fotté		2 bevels	23	1018730	panaget.com
	Mix	Topaze				1018731	panaget.com

The finger-joint allows to simulate a real random length wood floor.

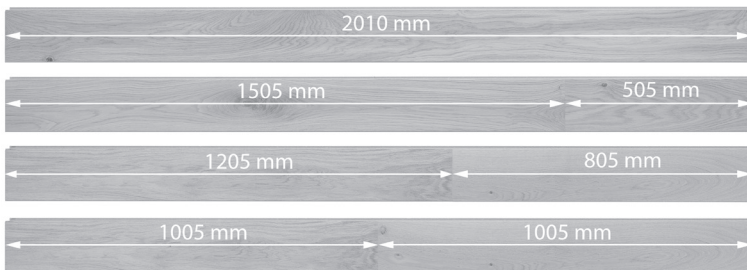

By order:
25% of full length planks
75% of finger-jointed planks

Package made up of 7 planks (for the 139) and 5 planks (for the 184)
1 plank can be replaced by 2 planks, equivalent to 2010 mm.
- 1505 + 505 mm
- 1205 + 805 mm
- 1005 + 1005 mm

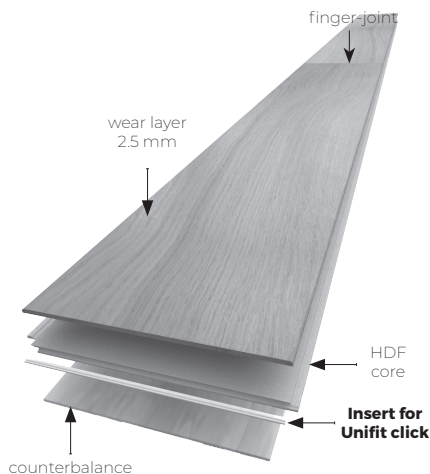

CHARACTERISTICS	139	184
Twin & single-stave length <small>more details on pages 6 and 7</small>	2010 mm	2010 mm
Width	139 mm	184 mm
Thickness	12 mm	12 mm
Wear layer	2.5 mm	2.5 mm
Core	HDF	HDF

PACKING	139	184
Weight / sqm	9.9 kg	9.9 kg
Sqm / pack	1.96	1.85
Pack / pallet	45	48
Sqm / pallet	88.20	88.8



- floating installation using plastic DPM + Isol 20
- or fully glue down using our special presto PM glue



fully glue down using our special presto PM glue





ALTO 139x1210 / 12 MM CLICK UNIFIT

Engineered **twin & single stave** plank, HDF core - 2 bevels
Made under the patent EN 13489



Species	Grade	Finishes	Lacquer	Oil	Bevels type	Class of use	Item number	Photo on the catalogue 2022-23 or on
FRENCH OAK	Tradition	Bois flotté					1017696	panaget.com
	Tradition	Café crème					1020643	panaget.com
	Tradition	Sable			2 bevels	23	1017896	page 29
	Tradition	Satin					1017699	panaget.com
	Tradition	Topaze					1017700	panaget.com
		Zenitude (<i>rustic</i>)	Shabi chaud			2 bevels	23	1017702

Single plank
Finger-jointed lengths

The finger-joint allows to simulate a real random length wood floor.

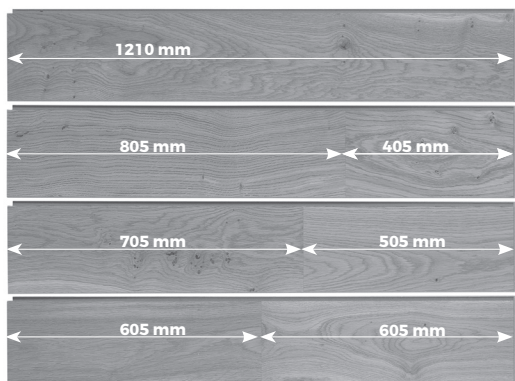

By order:
25% of full length planks
75% of finger-jointed planks

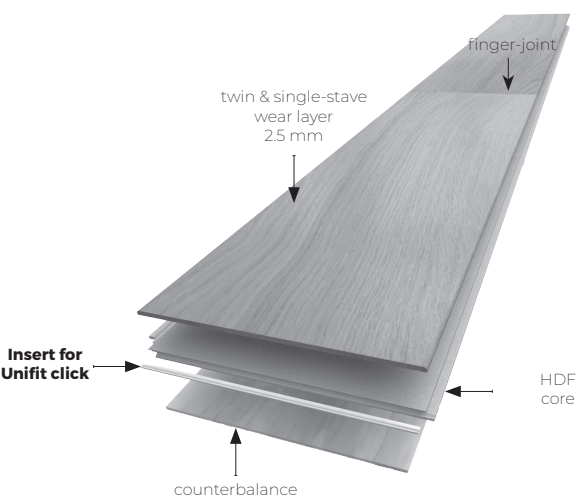

CHARACTERISTICS

Twin & single-stave length 1210 mm
 1 plank = 1210 mm (25% minimum garantie par commande)
 1 plank = 805 + 405 mm
 1 plank = 705 + 505 mm
 1 plank = 605 + 605 mm

Width 139 mm
 Thickness 12 mm
 Wear layer 2.5 mm
 Core HDF

PACKING

Weight / sqm 9.9 kg
 Sqm / pack 1.85
 Pack / pallet 45
 Sqm / pallet 83.25



- floating installation using plastic DPM + Isol 20
 - or fully glue down using our special presto PM glue



fully glue down using our special presto PM glue





SINGLE PLANK 139 / 12 MM CLICK UNIFIT

Engineered single plank to **fixed length**, HDF core - 2 bevels
Made under the patent EN 13489



Species	Grade	Finishes	Lacquer	Bevels type	Class of use	Item number	Photo on
Single plank 139							
FRENCH OAK	Mix	Bois flotté				1017681	panaget.com
	Mix	Linen				1017682	panaget.com
	Mix	Opale		2 bevels	23	1017683	panaget.com
	Mix	Topaze				1017684	panaget.com

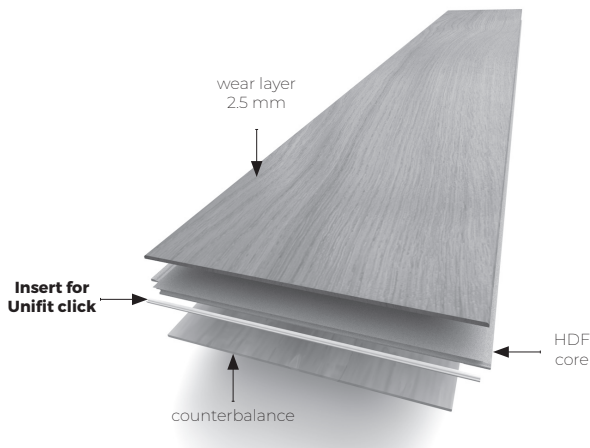

CHARACTERISTICS

Length more details on pages 6 and 7	1210 mm
Width	139 mm
Thickness	12 mm
Wear layer	2.5 mm
Core	HDF



- floating installation using plastic DPM + Isol 20
- or fully glue down using our special presto PM glue



fully glue down using our special presto PM glue

PACKING

Weight / sqm	9.9 kg
Sqm / pack	1.85
Pack / pallet	45
Sqm / pallet	83.25





ORFÉO 139 / 14 MM CLICK

Engineered two-strip to **fixed length**, HDF core - square edged
Made under the patent EN 13489



Species	Grade	Finishes	Lacquer	Oil	Bevels type	Class of use	Item number	Photo on the catalogue 2022-23 or on
FRENCH OAK	Classic (select)	Bois flotté					1005750	panaget.com
	Classic (select)	Satin			square edged	31	1005751	panaget.com
	Classic (select)	Topaze					1020735	panaget.com
	Tradition	Saphir			square edged	31	1006929	panaget.com
	Tradition	Satin			square edged	31	1006920	page 17

Fixed length

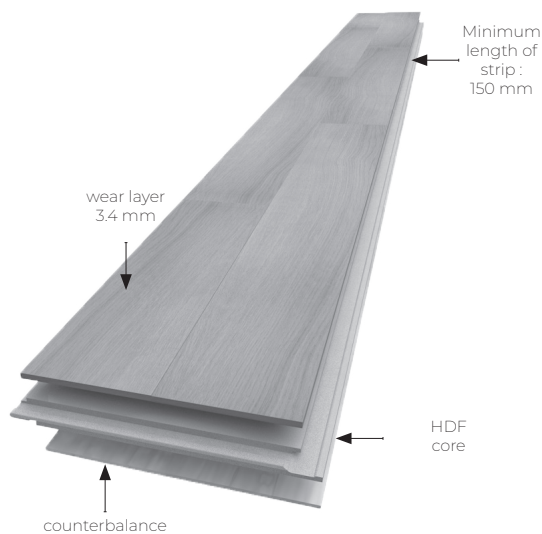

CHARACTERISTICS

Length	1500 mm
more details on pages 6 and 7	
Width	139 mm
Thickness	14 mm
Wear layer	3.4 mm
Core	HDF



- floating installation using plastic DPM + Isol 20
- or fully glue down using our special presto PM glue

PACKING

Weight / sqm	11.8 kg
Sqm / pack	1.46 (7 planks)
Pack / pallet	50
Sqm / pallet	73.00





CHEVRON 90 OR 139 / 14 MM TONGUE & GROOVE

Engineered single plank, chevron pattern, plywood core, 4 bevels
Made under the patent EN 13489



Species	Grade	Finishes	Lacquer	Oil	Bevels type	Class of use	Item number	Photo on the catalogue 2022-23 or on
Chevron 90								
FRENCH OAK	Classic (select)	Satin			4 bevels	31	1005742	panaget.com
	Classic (select)	Topaze						
	Authentic (middle grade)	Bois flotté			4 bevels	31	1019719	panaget.com
	Zenitude (rustic)	Tufeau			4 bevels	31	1019720	page 78

Species	Grade	Finishes	Lacquer	Oil	Bevels type	Class of use	Item number	Photo on the catalogue 2022-23 or on	
Chevron 139									
FRENCH OAK	Authentic (middle grade)	Bois flotté			4 bevels	31	1019821	page 79	
	Authentic (middle grade)	Café crème							
	Authentic (middle grade)	Sable			4 bevels	31	1019823	panaget.com	
	Authentic (middle grade)	Topaze			High Traffic Lacquer	4 bevels	31	1021064	panaget.com
	Zenitude (rustic)	Miel			4 bevels	31	1019824	page 82	

Length on surface:

- Chevron 90: 500 mm
- Chevron 139: 650 mm

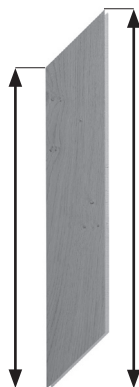

Point-to-point length:
- Chevron 90: 589 mm
- Chevron 139: 789 mm

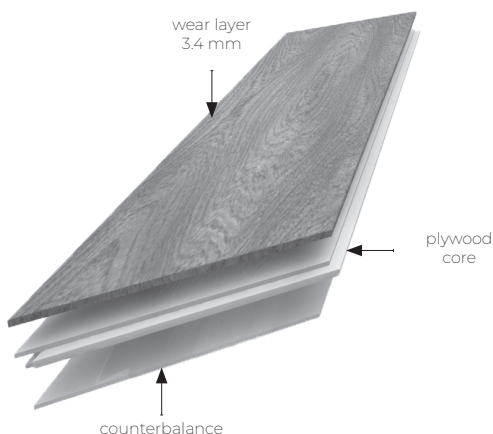
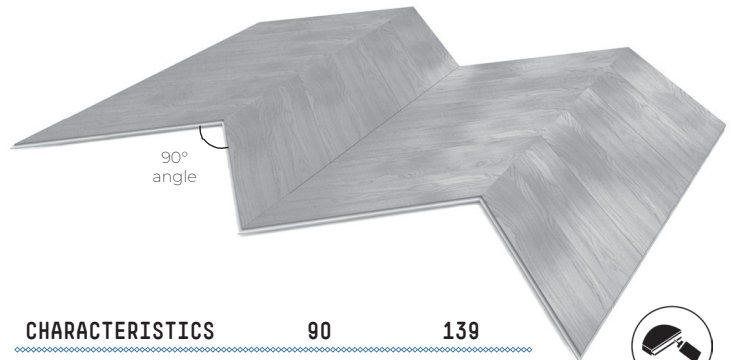

CHARACTERISTICS

	90	139
Length more details on pages 6 and 7	500 mm	650 mm
Point-to-point length	589 mm	789 mm
Width	90 mm	139 mm
Thickness	14 mm	
Wear layer	3.4 mm	
Core	plywood	



- floating installation
gluing T&G and using
plastic DPM + Isol 20
- or fully glue down using
our special presto PM glue

PACKING

	90	139
Weight / sqm	7.4 kg	7.4 kg
Sqm / pack	1.26	1.45
Pack / pallet	32	32
Sqm / pallet	40.32	46.40





HERRINGBONE 90 OR 139 / TONGUE & GROOVE

Engineered single plank, herringbone pattern, 4 bevels
Made under the patent EN 13489



Species	Grade - Surface aspects	Finishes	Lacquer	Oil	Bevels type	Class of use	Item number	Photo on the catalogue 2022-23 or on
Herringbone 90								
FRENCH OAK	Classic/Authentic	Habano	☾				1016742	panaget.com
	Classic/Authentic	Linen	☾				1005924	page 72
	Classic/Authentic	Satin	☀		4 bevels	23	1016745	panaget.com
	Classic/Authentic	Topaze	☾				1020644	panaget.com
	Classic/Authentic	Tufeau		👉			1016743	panaget.com
Herringbone 139								
FRENCH OAK	Authentic (middle grade)	Bois flotté	☾		4 bevels	31	1016617	page 73
	Authentic (middle grade)	Topaze	☾				1016618	pages 74-75
	Zenitude (rustic)	Bois flotté	☾	High Traffic Lacquer	4 bevels	31	1021063	panaget.com
	Zenitude (rustic)	Miel	☾		4 bevels	31	1021342	panaget.com
	Zenitude-Origine	Flanelle					1007655	panaget.com
	Zenitude-Origine	Shabi chaux		👉	2 aged bevels	31	1015715	panaget.com
	Zenitude-Origine	Tufeau		👉			1007658	panaget.com
FLAMED BEECH	Bois flotté		☾		4 bevels	31	1021454	panaget.com
	Satin		☀				1021455	panaget.com
US WALNUT*		Satin	☀		4 bevels	21	1019564	pages 76-77

*US walnut is very sensitive to UV-light causing colour variations over the years. It should therefore not be laid in front of large windows.

Herringbone 90

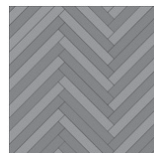
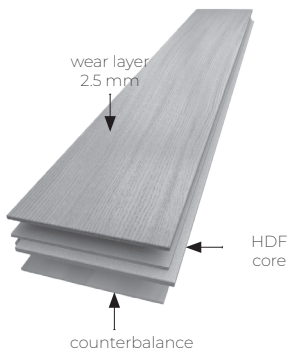

CHARACTERISTICS	HB 90	HB 139 / Walnut
Length <small>more details on pages 6 and 7</small>	590 mm	800 mm
Width	90 mm	139 mm
Thickness	12 mm	14 mm / 13 mm
Wear layer	2.5 mm	3.4 mm / 2.5 mm
Core	HDF	plywood



- floating installation gluing T&G and using plastic DPM + Isol 20
- or fully glue down using our special presto PM glue

Herringbone 139

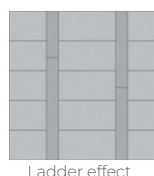

Only Walnut Herringbone 139 is 13 mm thick with a wear layer of 2.5 mm.

PACKING	HB 90	HB 139 / Walnut
Weight / sqm	9.9 kg	7.4 kg
Sqm / pack	1.91	2.22 / 2.45
Pack / pallet	32	32
Sqm / pallet	61.12	71.04 / 78.40



- in 90, fully glue down using our special presto PM glue
- in 139, not compatible





CARMEN / 14 MM TONGUE & GROOVE

A unique engineered hand-made marquetry panel format, plywood core, square edged
Made under the patent EN 13489



Species	Grade	Finishes	Lacquer	Bevels type	Class of use	Item number	Photo on the catalogue 2022-23 or on
FRENCH OAK	Classic <i>(select)</i>	Satin n°1				1005715	panaget.com
	Classic <i>(select)</i>	Satin n°2		square edged	31	1005714	page 84
	Classic <i>(select)</i>	Satin n°5				1005712	panaget.com

You can border Carmen panels with **square edged** Diva 139 planks.

FRENCH OAK	Classic <i>(select)</i>	Satin		square edged	31	1005748	panaget.com
------------	-------------------------	-------	--	--------------	----	---------	-------------

This parquet is hand-made and may not be perfectly centered.

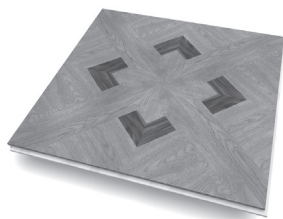

CARMEN N°1
Merbau inlays

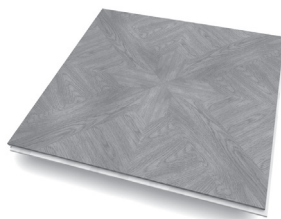

CARMEN N°2

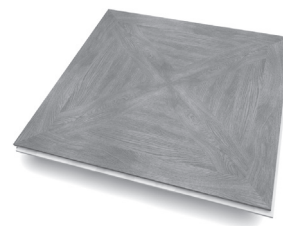

CARMEN N°5

CHARACTERISTICS

Length	392 mm
more details on pages 6 and 7	
Width	392 mm
Thickness	14 mm
Wear layer	3.2 mm
Core	plywood



- floating installation
gluing T&G and using
plastic DPM + Isol 20
- or fully glue down
using our special presto
PM glue (à privilégier)

PACKING

Weight / sqm	10.8 kg
Sqm / pack	1.23 sqm (8 tiles)
Pack / pallet	42
Sqm / pallet	51.66 sqm

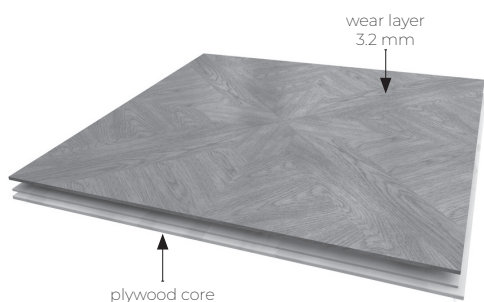



HIGH TRAFFIC

The flooring range for specific public areas



Species	Grade	Finishes	Lacquer	Oil	Bevels type	Class of use	Item number	Photo on
DIVA 139 / 14 MM CLICK - Technical data and packaging to be found on page 14								
FRENCH OAK	Authentic (middle grade)	Bois flotté					1021037	panaget.com
	Authentic (middle grade)	Café crème			4 bevels	31	1021038	panaget.com
	Authentic (middle grade)	Topaze					1021039	panaget.com

Species	Grade	Finishes	Lacquer	Oil	Bevels type	Class of use	Item number	Photo on
DIVA 184 / 14 MM CLICK - Technical data and packaging to be found on page 17								
FRENCH OAK	Zenitude (rustic)	Bois flotté			4 bevels	31	1021048	panaget.com
	Zenitude (rustic)	Miel					1021061	panaget.com

Species	Grade	Finishes	Lacquer	Oil	Bevels type	Class of use	Item number	Photo on
DIVA 184 / 15 MM TONGUE & GROOVE - Technical data and packaging to be found on page 19								
FRENCH OAK	Authentic (middle grade)	Bois flotté			4 bevels	33	1021062	panaget.com
	Authentic (middle grade)	Topaze					1019081	panaget.com

Species	Grade	Finishes	Lacquer	Oil	Bevels type	Class of use	Item number	Photo on
CHEVRON 139 / 14 MM TONGUE & GROOVE - Technical data and packaging to be found on page 24								
FRENCH OAK	Authentic (middle grade)	Topaze			4 bevels	31	1021064	panaget.com

Species	Grade	Finishes	Lacquer	Oil	Bevels type	Class of use	Item number	Photo on
HERRINGBONE 139 / 14 MM TONGUE & GROOVE - Technical data and packaging to be found on page 25								
FRENCH OAK	Zenitude (rustic)	Bois flotté			4 bevels	31	1021063	panaget.com

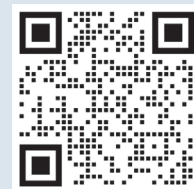

For more information, scan this QR code:



SONATE 90 OR 140 / 14 MM TONGUE & GROOVE

Solid single plank, 4 bevels
Made under the patent EN 13226



Species	Grade	Finishes	Lacquer	Oil	Bevels type	Class of use	Item number	Photo on the catalogue 2022-23 or on
Sonate 90								
FRENCH OAK	Authentic (middle grade)	Natural oil					1000026	panaget.com
	Authentic (middle grade)	Satin			4 bevels	34	1000027	panaget.com
	Authentic (middle grade)	Topaze					1000028	page 21
	Zenitude (rustic)	Bois flotté			4 bevels	34	1007293	panaget.com
	Zenitude (rustic)	Miel					1020645	panaget.com

Species	Grade - Surface aspects	Finishes	Lacquer	Oil	Bevels type	Class of use	Item number	Photo on the catalogue 2022-23 or on	
Sonate 140									
FRENCH OAK	Classic (select)	Topaze			4 bevels	34	1017918	panaget.com	
	Authentic (middle grade)	Cuir					1021341	panaget.com	
	Authentic (middle grade)	Natural oil			4 bevels	34	1000033	page 24	
	Authentic (middle grade)	Saphir					1000031	panaget.com	
	Authentic (middle grade)	Topaze					1000034	panaget.com	
	Zenitude (rustic)	Bois flotté					1007261	panaget.com	
	Zenitude (rustic)	Café crème				4 bevels	34	1019819	panaget.com
	Zenitude (rustic)	Linen					1007268	panaget.com	
	Zenitude (rustic)	Miel					1019820	page 28	
	Zenitude-Origine	Cuir			4 with 2 aged	34	1006531	panaget.com	

Sonate 90

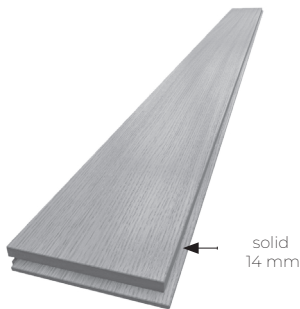

Sonate 140

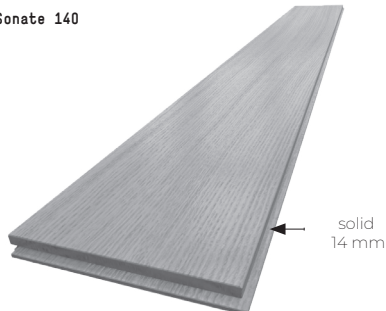

CHARACTERISTICS

Lengths
more details on pages 6 and 7

Width
Thickness
Wear layer

Sonate 90 Sonate 140

400 to 1300 mm
except Zenitude-Origine
500 to 1300 mm

90 mm 140 mm
14 mm 14 mm
7 mm 7 mm



fully glue down
using our special
presto PM glue

PACKING

Weight / sqm
Sqm / pack
Pack / pallet
Sqm / pallet

Sonate 90 Sonate 140

10.7 kg 10.7 kg
1.64 1.64
32 40
52.48 65.60





ULYSSE / 12MM TONGUE & GROOVE

Solid single plank boat deck
Made under the patent EN 14342

Species	Finish	Oil	Bevels type	Class of use	Item number	Photo on the catalogue 2022-23
TEAK	Pre-oiled		square edged	22	1021425	page 69
Maintenance	Soap		1 liter / 400 sqm to be dilue with water		1001883	
	Natural oil in bottle		1 litre / 100 sqm when sprayed		1001885	

After installation, apply a thin coat of Panaget natural maintenance oil.

Boat deck wood floors dedicated to bathrooms and wet areas

Not compatible with stagnant water. Do not use inside the shower or outside the pool.

CHARACTERISTICS

Lengths	300 to 1200 mm
Width	90 mm
Thickness	12 mm
Wear layer	4 mm

PACKING

Weight / sqm	8.4 kg
Sqm / pack	1.30
Pack / pallet	48
Sqm / pallet	62.40



fully glue down using our special presto PM glue



fully glue down using our special presto PM glue



Ulysse teak, integrated black rubber

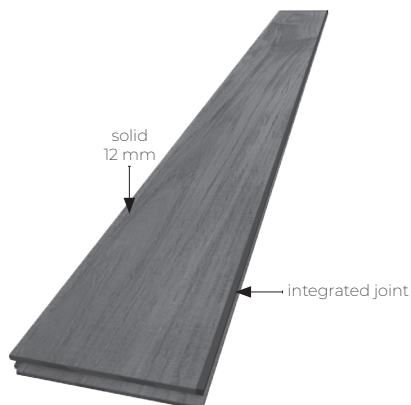



AGED FLOORING

BY PANAGET



ZENITUDE-ORIGINE

The aged look of the Origine aspect is inspired by the raw, natural beauty of oak. The strips are chosen at the sawmill for their peculiarities (knots, cracks, colour variation...) developed over the oaks growth.

Each strip is **bevelled lengthwise using traditional aging techniques**, brushed to highlight the uniqueness of the wood, and to give a simple, silky oil finish.

Species	Formats	Grade - Surface aspects	Finishes	Oil	Bevels type	Class of use	Item number	Photo on the catalogue 2022-23 or on
FRENCH OAK	Diva 139/14 tongue and groove*	Zenitude-Origine	Cuir		2 aged bevels	31	1006522	pages 58-59
		Zenitude-Origine	Sable				1016633	panaget.com
		Zenitude-Origine	Tufeau				1006521	panaget.com
	Diva 184/14 tongue and groove*	Zenitude-Origine	Cuir		2 aged bevels	31	1006550	panaget.com
		Zenitude-Origine	Sable				1016635	panaget.com
		Zenitude-Origine	Tourbe				1006552	panaget.com
		Zenitude-Origine	Tufeau				1006551	pages 38-39
	Herringbone 139*	Zenitude-Origine	Flanelle		2 aged bevels	31	1007655	panaget.com
		Zenitude-Origine	Shabi chaux				1015715	panaget.com
		Zenitude-Origine	Tufeau				1007658	panaget.com
Sonate 140/14 (solid)*	Zenitude-Origine	Cuir		4 with 2 aged	34	1006531	panaget.com	

* You can find the technical specification of the Zenitude-Origine collection here:
 Diva 139/14 in page 15 / Diva 184/14 in page 18 / Herringbone 139 in page 25 / Sonate 140 in page 28

ZENITUDE-SALVAGIO

When we say our flooring is aged, we actually mean it. The distinctive, **rough-cut look** of the **Salvagio** aspect is achieved by carefully selecting the boards in our workshops: they come in different thicknesses, completed with saw marks, discolourations, cracks and tannin marks. These **natural features** give a blend of elegance, character, and vintage appeal.

The planks are brushed to give a traditional look along with a silky oil finish.

Species	Format	Grade - Surface aspects	Finishes	Oil	Bevels type	Class of use	Item number	Photo on the catalogue 2022-23 or on
FRENCH OAK	Diva 139/14 tongue and groove*	Zenitude-Salvagio	Grey oil		2 bevels and sawing marks	31	1014171	page 51
		Zenitude-Salvagio	Natural oil				1014172	page 25

* You can find the technical specification of the Zenitude-Salvagio collection here:
 Diva 139/14 in page 15

SHABI

Based on our advanced manufacturing expertise, we have accurately reproduced the faded appearance of aged flooring, as well as preserve... Shabi: a uniquely original reminder that time never stands still.

Species	Formats	Grade - Surface aspects	Finishes	Oil	Bevels type	Class of use	Item number	Photo on the catalogue 2022-23
FRENCH OAK	Alto 139x1210 12 click Unifit*	Zenitude	Shabi chaux		2 bevels	23	1017702	page 32
		Zenitude-Origine	Shabi chaux				1015715	panaget.com

* You can find the technical specification of the Shabi collection here:
 Alto 139x1210 in page 21 / Herringbone 139 in page 25



MULTI-WIDTHS

Discover the French installation by combining the three widths we offer: Diva 90, Diva 139 and Diva 184.

Species	Grade	Finishes	Lacquer	Oil	Bevels type	Class of use	Item number	Photo on
DIVA 90 / 12 MM CLICK - Technical data and packaging to be found on page 12								
FRENCH OAK	Authentic (<i>middle grade</i>)	Cuir		☼	4 bevels	23	1014174	panaget.com
	Zenitude (<i>rustic</i>)	Bois flotté	☾		4 bevels	23	1015663	panaget.com

Species	Grade	Finishes	Lacquer	Oil	Bevels type	Class of use	Item number	Photo on
DIVA 139 / 12 MM CLICK - Technical data and packaging to be found on page 13								
FRENCH OAK	Authentic (<i>middle grade</i>)	Cuir		☼	4 bevels`	23	1014176	page 60
	Zenitude (<i>rustic</i>)	Bois flotté	☾		4 bevels`	23	1007643	page 13

Species	Grade	Finishes	Lacquer	Oil	Bevels type	Class of use	Item number	Photo on
DIVA 184 / 12 MM CLICK - Technical data and packaging to be found on page 16								
FRENCH OAK	Authentic (<i>middle grade</i>)	Cuir		☼	4 bevels	23	1014179	panaget.com
	Zenitude (<i>rustic</i>)	Bois flotté	☾		4 bevels	23	1016424	panaget.com



French oak Authentic Cuir, Multi-widths



French oak Zenitude Bois flotté, Multi-widths

Watch the French installation video:

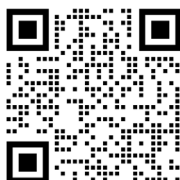



LAYING

ACCESSORIES

Get the job off to a good start with our laying accessories!
You need the right information, the right tools and to be well-prepared.
To ensure wood floor is durable and stable, it needs to be laid under the right conditions.

UNDERLAYS

The choice of the underlay is an essential step to ensure the quality of the installation and the final satisfaction of the wood floor. Mandatory for floating installation, it can also be used for glued installation (Isol 40) to reduce noise transmission between floors.

Underlays type	spm per roll	Thickness	Width	Compatibility underfloor heating	Item number
ISOL 20 2 mm non-reticulated polyethylene based underlay for floating installation.	25 sqm	2 mm	1 linear meter	Yes	1001662
ISOL 30 3 mm non-reticulated polyethylene foam and polyane (200 µ) underlay for floating installation.	15 sqm	3 mm	1 linear meter	No	1001661
ISOL 40 2mm natural underlay based on rubber and cork for floating or glued installation.	15 sqm	2 mm	1 linear meter	Yes	1014106

SPECIAL WOOD FLOORING GLUES

For an optimal result, we recommend the use of Panaget glue, designed and adapted to our wood floors and accessories.

Glue type	Use	Packing	Consumption	Item number
 PRESTO PM* Single-component glue based on a polymer that cross-links when in contact with the humidity of the air or the substrate.	Suitable for fully glue-down installation of solid and engineered wood floors. Imperative on underfloor heating/cooling.	7,5 kg packet	1,2 kg / sqm	1017921
		2 packet / bucket = 15 kg		1017922
		*Application of Presto PM glue with the Panaget 4x4 notched trowel - B3 teeth - steel blade		1001870
PRESTO BIB Vinyl glue in aqueous dispersion.	For tongue & groove floating installation or for the first row of a click wood floor.	500 g bottle	10 to 15 sqm	1001658
PRESTO GUN Water-based acrylic glue fast and strong setting.	For fixing skirtings, profiles and other accessories.	310 ml cartridge	12 to 15 linear meter	1001656









FINISHING

ACCESSORIES

Enhance your room with our finishing accessories!
The accessories you choose can be almost as important as the type of wood floor you go for.
The right finishing can really make a difference to perfect your room.

SKIRTING BOARDS [oak veneer on MDF lacquered, unfinished or white]

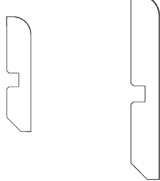
Panaget offers different **skirting boards**: **lacquered** (choice of available finishes), **unfinished** to match the colour of the wood floor (tinted with our finishing oils available on page 35), or **white** so that they can be painted to match the colour of your walls.

Profile type	Finishes	Dimensions in mm h x L x t	Quantity sold only per pack	Item number
LACQUERED VENEERED OR UNFINISHED - SQUARE FORMAT				
	Bois flotté (Bois naturel oil)	80 x 2200 x 14	6 / pack Per complete pack only	1020395
	Café crème			1020399
	Cuir			1020401
	Grey oil			1020400
	Sable (Amande)			1020398
	Topaze			1020394
	Tufeau			1020390
Unfinished	80 x 2200 x 14		1020389	
LACQUERED VENEERED - ROUND FORMAT				
 80 mm	Argile	78 x 2200 x 14	6 / pack Per complete pack only	1016625
	Fauve (Walnut)	80 x 2200 x 13		1002079
	Linen			1002080
	Saphir (Shabi chaux, White oil)			1001950
	Satin (Opale, Natural oil, Miel)			1002083
	Beech (Satin, Natural oil)			1002049
	Teak*			1002001
WHITE, READY TO BE PAINTED - ROUND FORMAT				
 58 mm 80 mm	White, ready to be painted	58 x 2200 x 13	6 / pack Per complete pack only	1014190
	White, ready to be painted	80 x 2200 x 13		1001991
VENEERED, WOODEN CORE MOULDING, GROOVE END				
	Satin	100 x 2200 x 13	6 / colis Per complete pack only	1002061
	PRESTO GUN (to fixe your skirting boards)	310 ml cartridge 12 to 15 linear meter	sold per unit	1001656

* While stocks last.





FINISHING

ACCESSORIES

DOORSILLS / THRESHOLDS

Panaget offers **profiles** that can be matched to the colour of the wood floor or can be stained with our finishing oils. The **3-in-1 profiles** can be cut to the desired shape to become a **threshold bar**, **connecting bar** or **stop bar**.

Profile type	Finishes (lacquered veneer or unfinished)	Dimensions in mm h x e x L	Quantity	Item number
2 in 1 oak veneered alu doorsills	Argile*	22 x 47 x 900	per unit	1016624
	Café crème			1020648
3 in 1 oak veneer doorsill on MDF	Cuir 	16 x 54 x 930	per unit	1021114
	Fauve (Walnut)*			1001976
	Linen / Bois flotté (Sable)			1001977
	Saphir (White oil, Shabi chaud)			1001972
	Satin (Opale, Natural oil, Miel)			1001980
	Topaze			1001978
	Tourbe (Cuivre)*			1001973
	Tufeau 			1021119
	Unfinished			1001979
	Linen / Bois flotté (Sable)			1014193
	Satin (Opale, Natural oil, Miel)			1014191
Topaze	1014192			
Unfinished	1001968			



NB: Finishes in parentheses are compatible with the reference finish. / *While stocks last.

THE 3-IN-1 PROFILES CAN BE CUT TO THE DESIRED SHAPE TO BECOME :

Junction bar

Case of junction between two coverings of the same level.

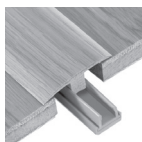

Threshold bar

Case of junction between two coverings of different levels.

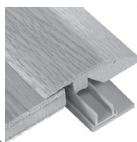

Stop bar

To finish off an installation in front of a window, for example.

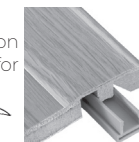

FINISHING PROFILES

		Dimensions in mm h x e x L	Quantity sold only per pack	Item number
Wood veneered quadrant (1)	unfinished French oak	12 x 12 x 2200	6 / pack	1001958
	satin lacquer French oak		Per complete pack only	1001959
Wood veneered scotia (2)	unfinished French oak	12 x 17 x 2200	6 / pack	1001956
	satin lacquer French oak		Per complete pack only	1001957
Wood veneered stair nosing (3) - Only compatible with 14 mm T&G wood floors	unfinished French oak	25 x 14 x 2150	10 / pack	1014008
	satin lacquer French oak			1001669
Radiator collar (4) - While stocks last	satin lacquer French oak	Ø 18	per unit	1001643
Wood veneered flat profile	unfinished French oak	4 x 30 x 2200	6 / pack Per complete pack only	1001955
Wood veneered corner profile	unfinished French oak	25 x 25 x 2200	6 / pack Per complete pack only	1001954



1

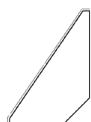

2

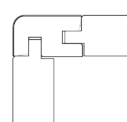

3

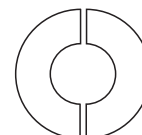

4



MAINTENANCE

ACCESSORIES

Look after your wood flooring!
There's nothing difficult about maintaining a Panaget wood flooring.
All you have to do is take into account its finish (lacquered or oiled) and the way it is used.

MAINTENANCE PRODUCTS

Panaget maintenance products are specially developed to care for your wood floor and preserve its original appearance. Panaget offers a maintenance solution for every floor, whether lacquered or oiled.

	Packing	Consumption	Item number	
LACQUERED WOOD FLOORING MAINTENANCE				
CLEANER FOR LACQUERED WOOD FLOORING				
The cleaner degreases, cleans and revives satin, matt or invisible lacquered wood floors.	1 liter bottle	1 liter / 400 sqm to be diluted with water	1001888	
RENOVATOR Maintains, renovates and protects. Specially adapted to lacquered wood floors subject to intense use, the renovator provides a homogeneous protective film covering the pores of the wood and thus preventing the adhesion of dirt. It provides long-lasting protection and makes maintenance easier.	For matt wood flooring	1 liter bottle	1001886	
	For satin wood flooring		1 liter / 50 sqm/ coat	1001887
OILED WOOD FLOORING MAINTENANCE				
SOAP				
Soft cleaner enriched with natural oils, it allows the regular maintenance of oiled wood floors.	1 liter bottle	1 liter / 400 sqm to be diluted with water	1001883	
NATURAL OIL				
Panaget maintenance oil penetrates into oiled wood floors and protects them for a long time while maintaining their natural appearance.		1 litre / 100 sqm when sprayed	1001885	
Bottle to RENOVATE oiled wood floors or STAIN unfinished accessories (other finishes on request)	Cabane, grey oil (CBM)		1013642	
	White oil		1001902	
	Bois flotté oil		1001897	
	Shabi chaux oil		1001891	
	Cuir oil		1001893	
	Flanelle oil	250 ml	ready-to-use 10 sqm/ bottle to renovate oiled wood floors	1001892
	Grey oil		or	1001901
	Natural oil		15 linear meter / bottle for staining	1001903
	Rafia oil			1001900
	Tourbe oil			1001898
Tufeau oil			1001896	

After installing the floor, apply a thin coat of Panaget's natural maintenance oil across the entire surface, regardless of the colour of the wood.



How protect my wood floor?

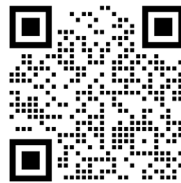

Maintaining my lacqued floor

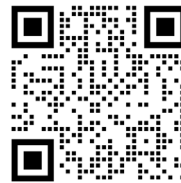

Maintaining my oiled floor

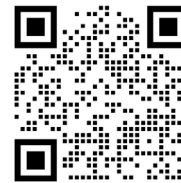

Tinting of accessories



THE PANAGET WALL COVERINGS REVOLUTION

BY PANAGET



2

Use exclusive Panaget mounting clip to fix strips to wall.

Use exclusive Panaget starter clip to fix first row of strips to THE TOP OF WALL.

1

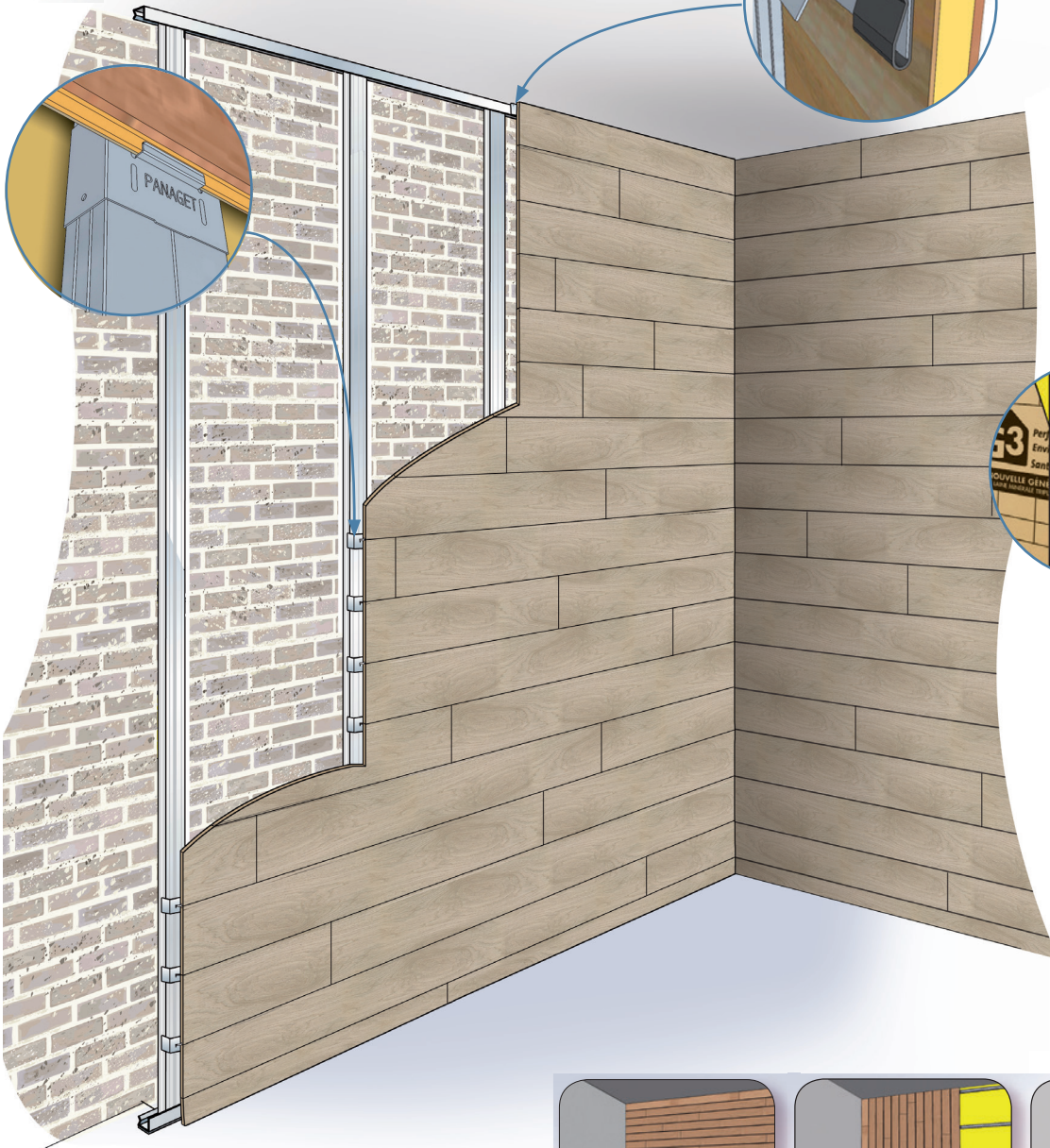
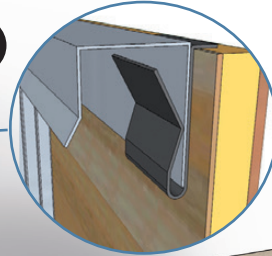

Use the right thickness for an ideal insulation and/or soundproof your home.

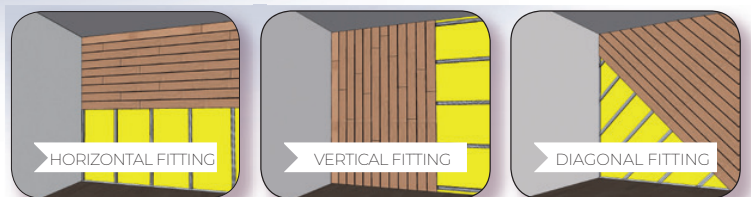

HORIZONTAL FITTING

VERTICAL FITTING

DIAGONAL FITTING



SCAN THE CODE to see picture of the whole range!

MADE-TO-MEASURE DECORATION: GIVE YOUR IMAGINATION FREE REIN.

Coordinate your floor and your walls thanks to our wide collection of wood flooring..



CONCEPT BOIS MURAL

A simple system to fix wall panelling on a metal frame system (such as F530 or S47) or can be also installed using traditional brackets



Format	Species	Finishes	Oil	Profile type	Item number	Photo in the catalogue 2022-2023 or on
Wall Panelling Duo 141	FRENCH OAK	Brut de récup		2.5 mm straight ship-lap profile	1018613	page 86
		Cabane, grey	🔹		1013614	pages 88-89
		Bois flotté	🔹	2.5 mm ship-lap profile	1001184	page 87
		Brushed unfinished		2.5 mm straight ship-lap profile	1019825	panaget.com
Wall Panelling 141	FRENCH OAK	Brut de récup		2.5 mm straight ship-lap profile	1016356	panaget.com
		Cabane, green	🔹		1001179	panaget.com
		White oil	🔹	2.5 mm ship-lap profile	1001186	page 92
		Rafia	🔹		1001183	page 91
		Tufeau	🔹		1001182	page 90

Mouting accessories	Packing	Use	Item number
Starter clip	box of 10	1 clip / ml	1001665
Mounting clip	box of 100	20 clips / sqm	1001666

Finishing accessories	Quantity sold only per pack	Item number	
Unfinished veneered oak quadrant		1001958	
Unfinished veneered oak scotia		1001956	
Unfinished veneered oak flat profile	6 / pack	1001955	
Unfinished veneered oak corner profile		1001954	
Bottles to stain your accessories	Cabane, grey oil	1013642	
	White oil	1001902	
	Bois flotté oil	ready-to-use 15 linear meter / bottle for staining	1001897
	Rafia oil	1001900	
	Tufeau oil	1001896	

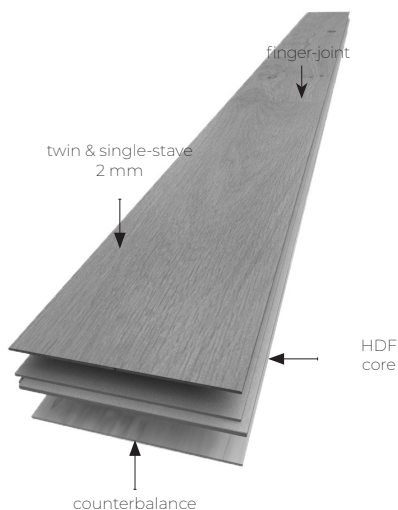

CHARACTERISTICS

Length	2005 mm, twin & single-stave
Width	141 mm
Thickness	10 mm
Core	HDF
Tongue & groove on 4 edges	

PACKING

Weight / sqm	8.1 kg
Sqm / pack	1.98 (7 planks)
Pack / pallet	30
Sqm / pallet	59.40





CLASSES OF USE

Introduction: classes of use are French standards, provided here for information purposes for countries other than France. In the specification tables, you have seen a class of use number for each type of wood flooring. This indicator involves its restoration and depends on the standard XPB53669. The tables below will help you understand what they mean. You can find the full European class on the internet.

Class of use	Description	Recommended use
Domestic use		
	areas with low or occasional footfall	rooms and corridors in a house with no access to outside
	areas with average footfall	living rooms with no outdoors access to outside and apartment entrance halls
	areas with high traffic	rooms with outdoors access or used for professional business purposes
Commercial use		
	areas with low or occasional footfall	single offices or hotel rooms
	areas with average footfall	libraries, churches and other places of worship, boutiques upstairs or with no direct access to outside, conference rooms
	areas with high traffic	airport lounges, boutiques with direct access to outside, nightclubs excluding actual dancefloors, lecture halls, auditoriums, reception halls upstairs, department stores upstairs, open-plan offices, stairs, IT offices, archives
	areas with very high traffic	multifunctional rooms, classrooms with direct access to outside, company restaurants, museums, public meeting rooms, pharmacies, publishing houses, tobacco shops, reception halls on the ground floor, large cafeterias, airport terminals

NB: The classes of use apply to products after sanding and machining and before surface treatment.

This standard does not apply to the maintenance of the appearance of the product pertaining to:

- the nature of the wood flooring,
- the quality of the surface protection (lacquered or oiled),
- the protection measures applied (sufficient mats at entrances, special protection under furniture and chairs),
- the adaptation of the finished wood flooring to meet the specific requirements of the location (intrinsic durability requirements but also appearance-related requirements),
- or sometimes the adaptation of occupants' way of life to the requirements of the wood flooring in order to allow an appearance-related requirement to be met (ban on heels that make a dent),
- routine care and maintenance carried out,
- restoration work carried out while the floor is being laid.

The UPEC (wear/punching stress/water/chemicals) classes, introduced by CSTB (the French Scientific and Technical Centre for Building), also define the classification of materials. In our case, they are not used because of potential restoration work on the wood flooring. As a guideline, for wood flooring with a wear layer of less than 4.5 mm, the classification would be U2P2E1C0.

Species	hardeness class	thickness ≥ 2.5 mm	thickness ≥ 3.2 mm	thickness ≥ 4.5 mm	thickness ≥ 7 mm
Walnut Teck	B: semi-hard wood	21	22	23	31
French Oak Beech	C: hard wood	23	31	33	34
Corresponding range of Panaget wood flooring		Diva 90 / 12 mm click Alto 139 / 12 mm click Alto 184 / 12 mm click Diva 139 / 12 mm click Diva 184 / 12 mm click Singleplank 139 / 12 mm click Herringbone 90 Herringbone 139 Walnut	Orfeo 139 / 14 mm click Diva 139 / 14 mm T&G Diva 139 / 14 mm click Diva 184 / 14 mm T&G Diva 184 / 14 mm click Carmen Herringbone 139 Chevron 90 & 139 Ulysse 90	Diva 184 / 15 mm T&G Diva 223 / 15 mm T&G	Sonate 90 & 140



PRACTICAL INFORMATION

COLOURS - HUES SHADES

Each wood floor plank is unique, as it is subject to vagaries of nature: variations in colour, size and number of knots, irregularity of wood grain, etc. There are all phenomena that the best theoretical classifications cannot channel.

Whether it is light or dark, the colour of your floor will change over time. Ultraviolet rays will change the shade of new wood, and if you move a carpet or a furniture, you will notice that the floor underneath is lighter than the surrounding area, though it will take on the colour of the surrounding wood after a few weeks. Walnut wood tends to be particularly affected by this phenomenon.

Wood naturally expands and contracts with changes of temperature and humidity – for example, when your heating system is switched on and off. Don't forget about the expansion gap. Beech and Maple wood floors will contract more than other types of wood. The drying effect caused by heating systems can cause greater shrinkage between the boards.

What is the expansion gap?

This is the free space that needs to be left around the edge of a room, pipes, the bottom of door frames and generally any other fixed point to enable the wood to expand. The expansion gap should be 1.5 mm for every linear metre of wood flooring installed with a minimum gap of 8 mm. Make a 1 cm-deep notch at the bottom of any wooden frames.

OPTIMAL CONDITIONS FOR WOODEN FLOORS

It is important to maintain humidity levels between 40% and 60% and a temperature of at least 15°C when installing the floor and throughout its lifetime. This enhances floor hold and ensures your comfort as well. You should monitor or regulate these levels by using a humidifier or dehumidifier, or by using certain plants. For example, Boston ferns help increase humidity levels whilst cactuses decrease them. These steps help ensure the floor remains even and prevent the wood from buckling or wearing.

If the heating and ventilation are switched off for long periods, for example, in a second home that is often unoccupied, this may cause the floor to warp. This might also happen when the floor is exposed to high temperatures for long periods, such as flooring beside a bay window or in a conservatory.

STORAGE

All premises need to adhere to the conditions specified above. Wood flooring delivered in its original packaging needs to be stored in the rooms where it will be installed or in a clean, dry and sheltered place, away from condensation and rising damp. Wood floor should be protected from the sun and never stored on the floor with underfloor heating switched on or on a still-drying subfloor. You should not open the packs of wooden flooring until the day you plan to install it.

PREPARING THE SITE

Wood floor should only be installed if the following conditions have been met:

- 1 - The windows have already been fitted and the rooms where the floor will be installed meet the specifications detailed above.
- 2 - In a new building, the floor needs to be installed AFTER work on the walls, including painting, wallpapering and mineral rendering, is completed, and the walls themselves are dry.
- 3 - The watertightness of sanitary and heating installations has been checked.
- 4 - The temperature of the premises has to be above 15°C, and the area has to be well ventilated. Taking into account the humidity level to which the flooring is exposed over time, the flooring should not be installed unless the humidity is between 40% and 60%. If this is not the case, all possible measures needs to be taken to achieve this level, for example, by heating up the rooms or using a dehumidifier. The humidity level relative to the air (40% to 60%) needs to be constantly maintained.
- 5 - Any risk of a rise in the humidity level of the premises during and after installation needs to be prevented.

THE GOLDEN RULES

The inherent nature of wood means a certain number of precautions need to be taken during each stage of floor installation: before, during and after installing the floor. They are outlined above, and can also be found on each package (floor installation guide with images on the back) as well as in the official DTU 51-2 "Glued Wood Floors" and 51-11 "Floating Wood Floors" guidelines. All of the documents related to your product (technical specification sheets, maintenance instructions, etc.) as well as practical information and advice on installing floors can be found on our website: www.panaget.com

For further technical information, get it with us via phone or our website.

SUBFLOOR

The subfloor should comply with the following requirements:

1 - Subfloor humidity:

- Traditional screed: 3% when depth is 4 cm or more.
- Low-temperature underfloor heating: 1.5%.
- Anhydrite (calcium sulphate-based liquid flow screed) screed: 0.5% throughout.
- Wooden subfloor, floorboard subfloor or wood-based panels: 12% measured with the detection pins of a moisture meter.

The subfloor needs to be completely watertight. When flooring is installed directly onto a solid earth base, a damp-proof membrane should be placed underneath. As a guide, you should allow at least 10 days drying time per cm of screed thickness. This period should be increased by 50% in wet weather.

2 - Levelling tolerances

An uneven screed is only acceptable within the following tolerances:

- rise of 5 mm maximum over 2 m.
- rise of 1 mm maximum over 20 cm.

If these conditions are not met, you need to use a levelling compound. Never use glue to compensate for irregularities in the subfloor.

MAINTAINING WOOD FLOOR HUMIDITY LEVELS

It is vital that the humidity levels of engineered and solid-wood floors are maintained at every stage, including once installation is completed. The planks are made from wood that has been dried for six to eight weeks until a humidity level of around 9% for solid wood and 7% for engineered wood is obtained. This humidity level needs to be constantly maintained.

QUALITY

Our wood floors are subject to continuous and strict quality controls. When unpacking the planks, if you notice any defects or anomalies that may negatively impact the floor's appearance when installed, we advise you to IMMEDIATELY halt the process and contact your retailer. We cannot be held responsible if you fail to respect one or more of these recommendations.

VARIABLE LENGTHS

The majority of planks from our ranges are delivered in packs of random lengths. We recommend to open several packs when installing the floor in order to mix and match different lengths and hues.

IMPORTANT INFORMATION

For glued installation: glue should be spread across the entire surface of the wooden floor when sticking it down.

Bead adhesive is not suitable for use on underfloor heating/cooling systems. Bead adhesive is only suitable for glueing tongue-and-groove wood floor to the floor in an English or brick bond installation.

For floating installation: subfloors with a thickness of more than 3 mm (excluding fibreboard panels) or those that are highly compressible should be avoided. For this reason, you cannot install the floor on top of carpet.



INSTALLATION ON LOW-TEMPERATURE UNDERFLOOR HEATING

Underfloor heating and cooling systems require special precautions in addition to those on the previous page.

Before you start working, check with your retailer that the flooring is compatible with your system. We do not recommend using jatoba, or maple species

in such situations, and the heat resistance of floor coverings and any intermediate layers (such as acoustic underlays) should not exceed 0.13 W/m²K for underfloor heating and 0.09 W/m²K for reversible floors.

Subject to these conditions, the surface temperature of finished floors should not exceed 28°C (82°F).

We advise against using carpets and low-lying furniture, as they can significantly affect the system's performance.

Hydronic underfloor heating

You must comply with all provisions of DTU 65.14, "Installation of hot-water floor heating."

This type of system allows the floor to be floated with an underlay. If you glue-down the full surface, you must use Presto PM glue.

Main installation requirements:

- The thickness of the covering layer on top of the heating system needs to be at least 5cm.
- The water temperature should not exceed 40°C (104°F)
- The heat output should not exceed 95 W/m².
- The system needs to be carefully regulated, particularly when it is switched on for the first time, but also throughout its working life, to ensure this temperature is not exceeded.

Starting up the system:

- The subfloor will already have dried naturally, but the room also needs to be preheated for at least three weeks before the flooring is installed, regardless of the time of year.
- Turn off the heating 48 hours before installing the wooden floor.
- Then switch it back on no sooner than a week after you have finished installation, increasing it by 5°C (41°F) per day until it reaches the right temperature.

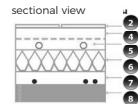
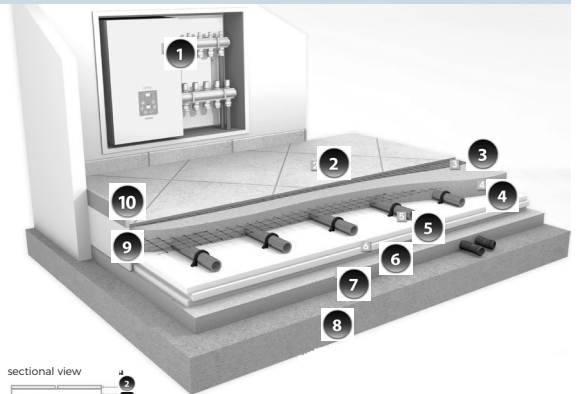

- | | |
|---|----------------------------------|
| 1 - Manifold | 6 - Isolant |
| 2 - Floor covering | 7 - Mortar bed if necessary |
| 3 - Floating with underlay or fully glued | 8 - Coreing slab |
| 4 - Floating screed | 9 - Edge band with sealing skirt |
| 5 - Cross-linked polyethylene | 10 - Skirting board |

Electric underfloor heating

Heated floors with electric cables buried in concrete must comply with NF C 32-330, and be installed in accordance with NF P 52-302 (formerly DTU 65-7).

Electric underfloor heating consisting of a heating cable covered with a screed or slab must comply with CPT Electric underfloor heating (CSB 3606).

The system also allows the floor to be floated with an underlay. If you glue-down the full surface, you must use Presto PM glue.

Main installation requirements:

- The covering layer above the heating elements should be at least 5cm thick.
- The heat output should not exceed 95 W/m².
- The temperature needs to be carefully regulated, particularly when the system is switched on for the first time, but also throughout its working life, to ensure that it does not rise too quickly.

Starting up the system:

- Electric radiant systems need to be started for the first time by an electric heating engineer.
- The subfloor will already have dried naturally, but the room also needs to be preheated for at least three weeks before the flooring is installed, regardless of the time of year.
- Turn off the heating for 48 hours before installing the floor.
- Then switch it back no sooner than a week after you have finished installation, increasing it by 5°C (41°F) per day until it reaches the right temperature.

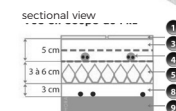
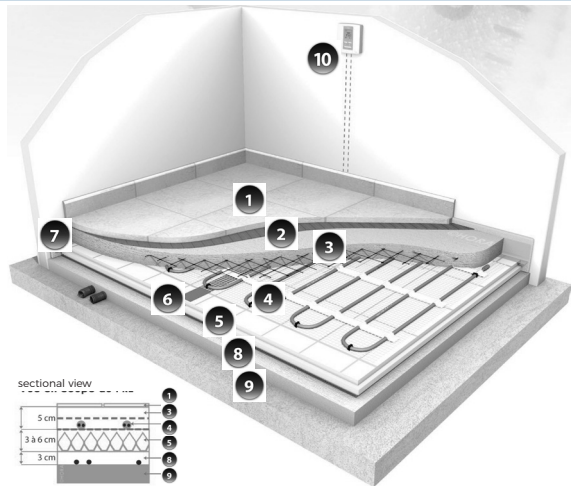

- | | |
|---|-----------------------------|
| 1 - Floor covering | 6 - Adhesive |
| 2 - Floating with underlay or fully glued | 7 - Edge strip |
| 3 - Floating screed | 8 - Mortar bed if necessary |
| 4 - Heating cable | 9 - Coreing slab |
| 5 - Insulation | 10 - Room thermostat |



LAYING ON A REVERSIBLE FLOOR HEATING/COOLING SYSTEM

You must glue the full surface to the floor using a PM glue and without an underlay (see glueing, page 39), and you must also comply with DTU 6514, "Installation of hot-water heated floors" and CPT "Low-temperature water-heated floors" (CSTB 3164).

Main installation requirements:

- The system must ensure that heat is evenly distributed across the surface.
- Fluid temperatures must be controlled by automatic probes to prevent underfloor condensation.
- The circuit must limit the fluid output temperature to between 18 and 22°C depending on the geographical region (see table below). The system installer must comply with this requirement.
- Heat emissions must not exceed 95 W/sqm.
- In summer, individual room thermostats should not be set below 22°C. The cooling system will not switch on until the ambient temperature is 25°C or less.

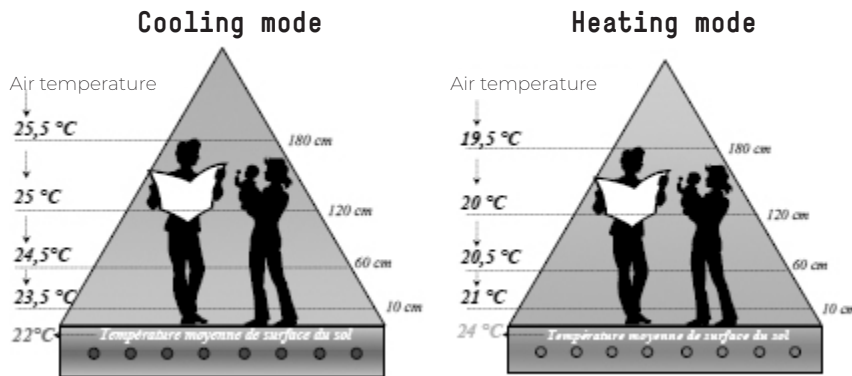

Starting up the system:

- The subfloor will already have dried naturally, but the room must also be preheated for at least three weeks before the flooring is installed, regardless of the time of year.
- You should then switch off the heating 48 hours before installing the flooring, and switch it back on three days after you have finished doing so. Then increase it by 5°C per day until it reaches the right temperature.



FITTING INSTRUCTIONS

LAYING INSTRUCTIONS FOR PANAGET WOOD FLOORS

Wondering how to install your wood flooring?
Looking for advice to choose your floor and get maintenance recommendations?

Visit our **tips page** on www.panaget.com and watch our **videos**.

Panaget floors won't have any secrets for you!

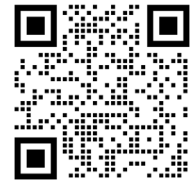

SCAN THE CODE
to watch our videos or join us on the Panaget Parquet Youtube channel.



Floating installation, click Unifit

Easy and fast, this click is also compatible with the JustClick!
Suitable for most supports.

----> Single plank 139 / Alto 139x1210 and Alto 139-184 x2010

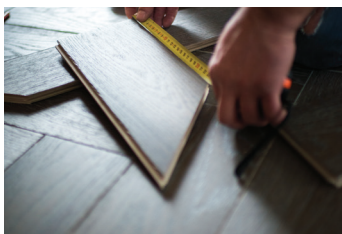

Floating installation, 2beclick

Assembly by gluing tongue and groove.
For engineered planks.

----> Orféo 139 / Diva 90, 139 and 184

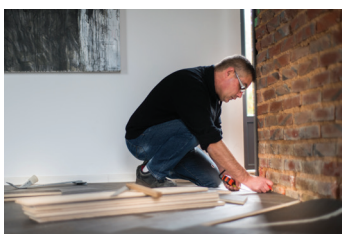

Floating glued installation

Assembly by gluing tongue and groove.
For engineered planks.

----> Diva 139, 184 and 223 / Carmen
Herringbone and Chevron

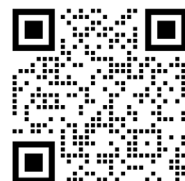

Herringbone installation



Chevron installation



Glue-down installation

Required for wet rooms, reversible heated floors, all solids and large trays. Wanted for sound comfort.

----> Sonate / Ulysse



Installation of Concept Bois Mural

Panaget's ingenious patented installation technology.
This new wall cladding in oak lets you change the whole look of a room in a few minutes.





DISCOVER THE PANAGET RANGE

Various communication tools are available to discover our range: the website www.panaget.com, the **catalogue 2022-2023** as well as **brochures** highlighting our new products or specific ranges.

You can also use **IMAGINE BY PANAGET**, the Panaget visualizer.

In a client meeting, use **IMAGINE BY PANAGET !**

What is it ?

A tool accessible from your smartphone, tablet or computer allowing you to visualize your interior with Panaget wood flooring.

Take a picture of your interior and choose the Panaget wood floor you like!

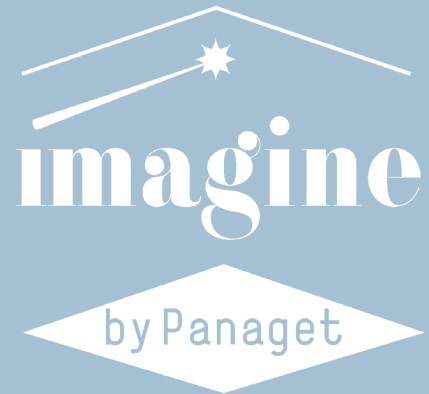

We explain here:

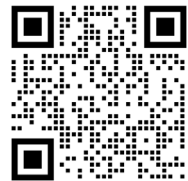

Downloadable **2022-2023 catalog** online. Discover and **share it** by mail or on social networks directly from our page.

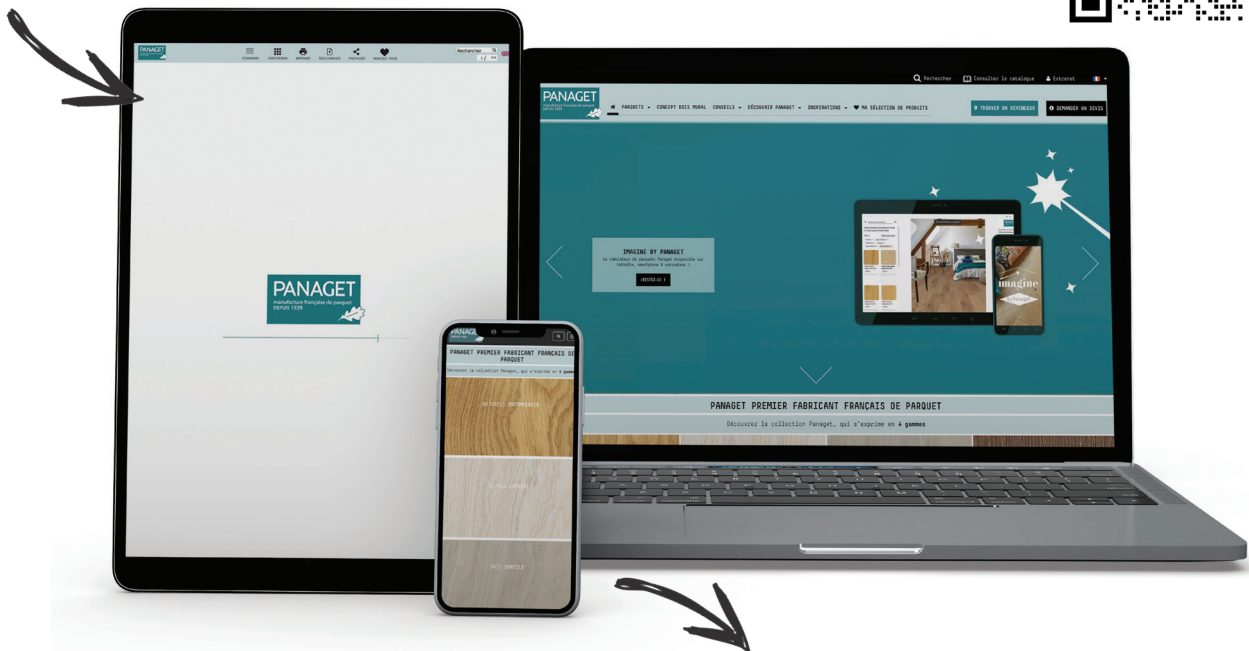

More than **173 references** sorted by color! Access each product and **technical sheet**.



YOUR PROJECTS INSPIRE US, SHARE THEM ON SOCIAL NETWORKS WITH **@PARQUETS.PANAGET** OR **#PANAGET**



WOOD FLOORS MAINTENANCE

Maintaining wood floors is becoming increasingly simple!

State-of-the-art finishing techniques ensure more and more efficient protection against everyday wear and tear, such as scratches and stains. However, it is still important to protect and clean your wood floor to ensure it retains its original appearance over the years.

For maximum durability, your Panaget flooring should only be subject to normal levels of wear and tear and should be properly maintained. This means taking precautions against damage caused by abrasive particules such as sand and gravel, as well as chair and table legs and castors on the bottom of armchairs, TV stands, etc. How long your floor lasts will depend on how well you look after it.

Steam cleaners and **warm or lukewarm water** should not be used to clean wood floors.

Protection and prevention:

Various problems can result from specific forms of use and lead to unsightly damage to the wood floor. Wood floor maintenance starts with the use of a rug at the doorway to the room as well as an absorbent doormat to capture any abrasive particles (sand, gravel, etc.).

Make sure to avoid any risk of unnecessary wear caused by unsuitable castors on pieces of furniture:

- Replace narrow plastic castors with wider rubber versions.
- If possible, place a rug or a translucent protection sheet under any armchairs or moveable furniture
- Cushion the bottom of tables and chairs with felt glides.

Don't forget that wood is a natural material and however hard it is, it can still be dented (by walking on it in high heels, for example).

Maintaining the humidity levels of wood floors:

To enhance floor hold and ensure your comfort, relative humidity should be kept between 40% and 60%, with an ambient temperature of 15°C (59°F).



Consult the Advice section of our website to discover all the tips for maintaining our wood floors.



How to protect my wood floor ?

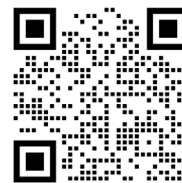

Maintain my lacquered wood floor

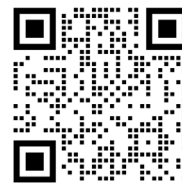

Maintain my oiled wood floor

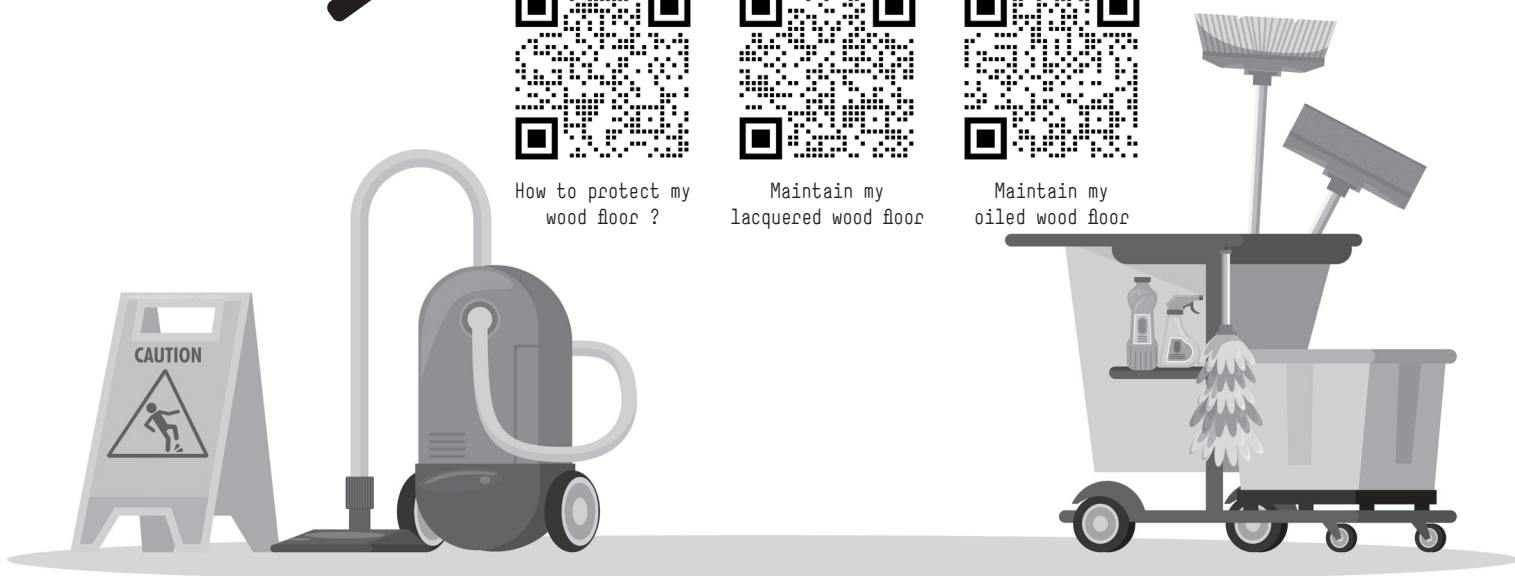



WOOD FLOORS MAINTENANCE

Lacquered wood floors maintenance

Maintenance:

Dust the floor on a daily basis using a vacuum cleaner.

In case of stains or ring marks, mop the floor with a wrung-out microfibre floor cloth, then dry it with kitchen roll. Cold water should always be used to clean the floors, no more than once a month. Use a neutral cleaning product (cf. page 35) if necessary, but avoid using any abrasive products or those containing silicone.

For brushed wood floors, we recommend occasional cleaning with a soft nylon brush, brushing in the same direction as the woodgrain.

Protection:

Following your own assessment of lacquer wear and tear, a protective matt, satin or metallic protective coating (Metalisant) can be applied to restore the original appearance of the lacquer. Make sure to vacuum up any dirt before applying a metallic coating and follow directions for use.

Oiled wood floors maintenance

Panaget's oiled finish is an impregnation oil that helps conserve the wood's natural appearance. The formula offers effective and long-lasting protection against stains and marks. To ensure your wood floor keeps its appearance over the years, it is very important to carry out the appropriate maintenance and follow the instructions below. Please note that certain cleaning products may contain wax or other unsuitable substances that can damage the surface of the wood. For this reason, we recommend using Panaget products.

After installing the floor, apply a thin coat of Panaget's natural maintenance oil across the entire surface, regardless of the colour of the wood.

Monthly maintenance:

- Oiled wood floors should be regularly dusted (with a broom or vacuum cleaner).
- To get rid of stubborn stains, use Panaget's natural soap.
- Always use cleaning tools that have been well wrung out and are not dripping (microfibre or sponge mops).
- Wood floors should only be cleaned with cold water.

Annual maintenance once or twice a year, depending on traffic:

Ensure the wood floor is clean and free of dust, then:

Apply Panaget maintenance oil, and wipe with a clean, dry cotton cloth, until full penetration of the oil.

Simple and sensible, regular maintenance regenerates the protective coating and preserves the natural, warm appearance of oiled wood floor.

Whichever finish you choose, caring for your wooden floor is extremely simple: all you need to do is regularly dust it with a damp cloth to remove soiling. Oiled wood floor calls for a little more care, for which reason we recommend treating it with a coat of maintenance oil regularly to ensure it keeps its shine.

Partial renovation can be carried out in areas where there is particular damage (cigarette burns, impacts, deep scratches, etc.).

Lightly take the gloss off the area using steel wool or sandpaper, until the damage has been removed.

In a container, mix the Panaget repair oil for at least three minutes, to ensure a fully consistent substance.

Use this mixture to reimpregnate the zone with a small brush or cloth in successive thin coats, until the touch-up cannot be seen.

The drying times for two-component Panaget repair oil are as follows:

Time required before recovering: 8 hours

Definitive curing: up to 6 days

L'EXPOZ,

— by Panaget —

DISPLAYS TO COMBINE ACCORDING TO YOUR DESIRES...



PREFER OUR ARRANGEMENTS EXPOZ' XS...

compositions comprising from 2 to 4 displays for the presentation of 16 to 34 samples.



Panaget can provide you with this display system for showcasing its references. Purposefully designed to be versatile yet very understated with some smart finishes, it can easily slot into any showroom to advertise the Panaget brand. The display system goes hand in hand with our catalogue and website, showcasing Panaget wood flooring and wall panellings in their best light and helping you boost sales. Our display system, designed perfectly to sit on its own, can also be doubled up to form coherent, smart-looking units.

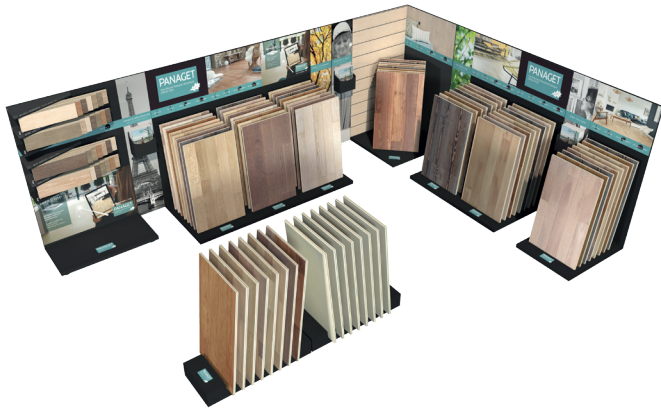

L-shaped display system >

16 sqm



Linear display system >

7.50 m long

L'EXPOZ

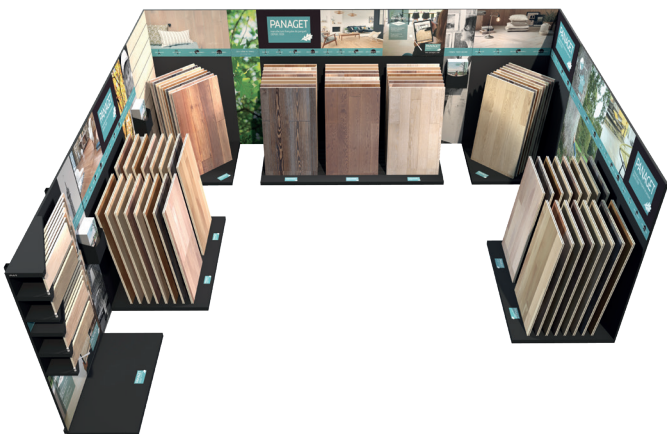

U-shaped display system >

17 sqm



Two-sided, back-to-back display system >

9 sqm

A set of our 72 standard products, mirroring exactly what can be found in our catalogue and on our website, to give customers a better overview of our entire range.



OUR 30 YEARS GUARANTEE

30-year contractual guarantee regarding the manufacturing of the wood flooring and wall panelling (excluding surface condition):

Thank you for choosing a high-quality product made in France. The manufacturing of our wood flooring and wall panelling is contractually guaranteed for 30 years, in line with normal usage of said products.

This 30-year contractual guarantee shall take effect on the date that appears on the invoice or proof of purchase, which should be kept with the corresponding 30-year guarantee certificate, with the batch number inscribed under the strips or on the inspection stamp.

Legal guarantees:

Independently of the contractual guarantee, our products are guaranteed against any lack of conformity and hidden defects, under the conditions set out in Articles L 211-4 et seq. of the French Consumer Code and Articles 1641 to 1649 of the French Civil Code.

[Article L. 211-4 of the Consumer Code

The seller must supply a product that complies with the contract, and is liable for any defects existing when it is delivered or resulting from packaging or assembly or installation instructions for which it is directly or indirectly responsible under the contract.]

[Article L.211-5 of the Consumer Code

To comply with the contract, the product must:

1: be suitable for the use one would normally expect of such an item and, if appropriate,

- comply with the seller's description and be of the same quality as any sample or model presented to the buyer;
- be of a quality which the buyer could justifiably expect given public statements made by the seller, the manufacturer or its agent, particularly in terms of advertising and labelling, or;

2: Have the agreed characteristics and be suitable for any specific use required by the purchaser and notified to and accepted by the seller.

[Article L217-12 of the Consumer Code

the right to take action concerning any lack of conformity shall lapse two years after the item is handed over.]

[Article L217-16 of the Consumer Code

Where the purchaser asks the seller, during the validity of the commercial guarantee that was granted to it when an item of moveable property was purchased or repaired, for restoration covered by the guarantee, any period lasting at least seven days during which the goods are out of use shall be added to the remaining duration of the guarantee.

That period shall start to run as soon as the purchaser requests intervention or makes the item in question available for repair if that is later than when the request for intervention was made.]

[Article 1641 of the Civil Code

The seller shall be liable for any hidden defects in an item sold that render it unsuitable for its intended use, or reduce its usefulness such that the buyer would not have acquired it, or would have paid a lower price, if they had known about it.]

[Article 1648, paragraph 1 of the Civil Code

The buyer must claim for hidden defects within two years of discovering them.]

Panaget shall not apply said contractual or legal guarantees:

- to downgraded or clearance Goods (Ecofloor and Utility grades);
- goods not paid for in full;
- to apparent defects not notified before or during the laying of the relevant Goods;
- to damage that is deliberate or caused by fair wear and tear, negligence, incorrect storage, an accidental act, an unplanned event or a case of force majeure;
- to goods not laid, used or stored in compliance with the recommendations contained in the corresponding User Guide or printed on the packaging or in our technical list;
- in the event of inadequate maintenance;
- in the event of a difference in appearance compared with that of samples which have not undergone the same exposure to UV radiation (patina);
- in the case of laying in rooms where water is in regular use (bathrooms, kitchens, etc.) unless the wood flooring or wall panelling is designed specifically for this purpose;
- if the product is installed in locations subject to significant changes in humidity, such as saunas, steam rooms and swimming pools;
- to defects related to failure to comply with the climatic conditions laid down and which would have been avoided if the humidity of the air had been regulated by the use of a humidifier or a dehumidifier and appropriate ventilation;
- if the product has been modified and/or repaired by you or a non-approved third party, with the exception of minor repairs carried out as part of the maintenance process;
- to wear due to penetration (stileto heels, etc.) of the wood and damage to the finish (lacquer, oil, colour, etc.) related to the use of the room.

Furthermore, said guarantees are limited to replacing defective Goods by supplying identical or similar goods and excludes the costs of lifting a laid floor, laying another floor and any damages and interest.

A reminder of certain installation/laying, usage and maintenance recommendations:

- The goods must be installed and laid in a way which meets all the implementation and humidity conditions as set out in our recommendations included with the Goods in question and in accordance with the implementation DTUs (French building regulations).
- The conditions required for installation in a Public-Access Building (PAB) must be known and fulfilled at the time of purchase.
- Maintenance must be carried out with the appropriate products.
- It is the purchaser's responsibility to maintain the ambient air in its premises at between 40% and 65% humidity and, where applicable, to regulate it using a humidifier or dehumidifier.
- Laying wood flooring or wall panelling in rooms where water is in regular use (bathrooms, kitchens, etc.) requires the use of an appropriate product (Ulysse) and/or requires measures to be put in place in order to prevent any risk for said wood flooring or wood panelling.
- The product must not be installed in wet areas such as shower trays and swimming pools.
- Wood flooring guaranteed for laying on floors with "low temperature" underfloor heating and/or for laying on floors with underfloor heating and cooling must be laid in accordance with the recommendations indicated in our current technical list or on the website.

Submitting a claim:

- If you encounter a problem, please stop installing our wood flooring or wall panelling immediately and consult us. If you wish to claim under the 30-year guarantee, please inform us by sending the corresponding guarantee certificate and the purchase invoice by registered mail with delivery confirmation, quoting the number on the back of the strips or the inspection stamp
- We may wish to inspect the defective product onsite.
- If we carry out an inspection and find that your claim is justified, our liability is limited to replacement of the defective product with an identical or similar one, and excludes the costs of lifting a laid floor, laying another floor and any damages and interest.
- If we repair the product under the guarantees mentioned above, and you are unable to use the product for seven days or more as a result, the remaining guarantee period will be extended by the same amount of time (Article L. 211-16 of the Consumer Code).

Our floor and wall coverings are made with a great deal of care and professional expertise, and this 30-year guarantee represents our commitment to your satisfaction.



GENERAL TERMS OF SALE

1 - GENERAL PROVISIONS

These terms and conditions are written in French in their original version, which alone shall be deemed authentic (middle grade) and shall take precedence over any other version translated into a foreign language.

These general terms and conditions shall apply in full to all sales of Goods (wood block flooring and accessories) made by Panaget to professional Clients starting on 01/01/2023. They are the fundamental and determining conditions and shall take precedence over any general conditions of purchase and any other documents issued by the Client, whatever the terms. Furthermore, any order sent to Panaget implies unconditional acceptance of Panaget's prices and these general terms and conditions.

2 - APPLICABLE LAW - JURISDICTION

Any question concerning these general terms and conditions, as well as the contracts to which they apply, shall be governed by French law.

In the event of a dispute, any difference concerning these general terms and conditions, as well as the contracts to which they apply, shall be dealt with only by the Trade Court of the town where Panaget has its registered office, even in the case of a summary ruling, proceedings against a guarantor which may take the form of giving third party notice, a summons or a plurality of defendants.

3 - ORDERS

Sales agreements are concluded validly only after written confirmation or the start of execution by Panaget of the corresponding orders. However, any order commits the Client as soon as it is issued regardless of the bearer or the signatory. Any amendment made by Panaget at the time it confirms the order shall be deemed accepted in full in the absence of a written refusal by the Client within two working days starting from the date of its communication and at the latest before its performance.

No order may be cancelled and/or assigned without Panaget's agreement.

4 - GOODS

They shall comply with the technical specification or, alternatively, with current AFNOR standards. The quota for the Goods (wood flooring and wall panelling) will be set per sqm.

5 - RESERVED TITLE

GOODS ARE SOLD WITH TITLE RESERVED UNTIL FULL PAYMENT HAS BEEN MADE. IN THIS RESPECT, PAYMENT MEANS CLEARED FUNDS SHOWING IN Panaget'S BANK ACCOUNT REPRESENTING THE PRICE OF THE GOODS, ANY CHARGES RELEVANT TO THE ORDER AND ANY INTEREST OWING.

In the event of non-payment, even partial, by the Client of a debt on the due date, Panaget shall be able specifically to claim the cost price of the unpaid Goods or recover same at the expense and risks of the Client, Goods in stock on the Client's premises being presumed as those unpaid.

Panaget shall retain any instalments paid as compensation, without prejudice to any other claim for reparations.

Modification and/or repacking of Goods still unpaid is prohibited. The Client may not under any circumstances pledge or mortgage Goods still unpaid, nor grant any securities over the latter. Finally, the Client may only resell Goods to which title is reserved for the normal needs of its business.

6 - DISPATCH - DELIVERY

6.1. For any order to be delivered in France, Panaget shall be deemed to have discharged its despatch & delivery obligation as soon as the Goods are delivered to the Client's registered office or to any other delivery point agreed with

However, the Client may, at its discretion, elect to collect the Goods personally at its own expense, risks and perils. It must inform Panaget of this at the time it places the order. The Goods shall be deemed delivered at the time they are supplied to the Client in Panaget's factories, stores or warehouses, or at any other place which the latter shall nominate. However, in this case, no price reduction will be made.

6.2. For any order to be delivered abroad, unless stipulated otherwise, the Goods will be delivered "ex works" (EXW, Incoterms ICC 2010).

6.3. Lead times are given for information only and failure to meet them shall not under any circumstances cause cancellation of the order or payment of compensation. Whatever the reason, the Client may not protest against any delay in delivery if it is not up to date with its obligations to Panaget, in particular as regards payment, or if Panaget was not in possession in good time of any specifications and/or information needed for the delivery.

7 - TRANSFER OF RISKS

Notwithstanding the reserved title clause mentioned in article 5 above, the Goods shall be deemed in the Client's custody as from the date of their despatch and delivery as set forth in article 6 above. Again, as from said despatch and delivery, the Client alone shall bear the risks which the Goods might suffer or cause, for any reason whatsoever, even in the event of force majeure, accident or act by a third party.

8 - COMPLIANCE - ACCEPTANCE

It is essential that the Client confirms compliance of the Goods (condition, absence of any apparent defect, quantity, etc. at the time of their receipt, in the presence, where relevant, of the

carrier; any costs or risks related to checking the Goods being the Client's responsibility.

If the Goods are collected by the Client, any reservation or dispute concerning an apparent non-compliance of the Goods must be recorded on the delivery note and confirmed to Panaget by registered letter with return receipt, within three days as from their collection.

Should Panaget arrange for the Goods to be shipped to the Client's premises, any reservation or dispute concerning an apparent non-compliance of the Goods must be recorded on the consignment note or CMR and confirmed to the carrier and to Panaget by registered letter with return receipt sent within 3 days (excluding public holidays) following taking delivery of the Goods. Failing compliance with these conditions, the Goods will be deemed compliant and Panaget's liability will not be challenged accordingly, the Client being held liable for any damage suffered by Panaget as a result of failure to comply with this procedure.

The Client will have to prove the existence of any shortfalls, defects and/or discrepancies relating to the Goods.

The appearance of any samples shall reflect as far as possible that of the Goods. Again, no claim for trivial differences of appearance with samples will be entertained.

9 - RETURNS - RECOVERY

No return of Goods will be accepted without express and prior agreement from Panaget.

Returned Goods must be in perfect condition, shall be returned in their original packing or packaging and shall not have been used and/or modified.

Any return accepted by Panaget shall generate, at the company's discretion, an exchange or a credit to be used against a later purchase, after qualitative and quantitative checking of the returned goods, no compensation being payable for any reason whatever.

In the event that Panaget agrees to take back Goods with no proven defect, said Goods shall be returned to Panaget by the Client at its own risk and expense, following the application of a discount of 20% on their invoiced price.

10 - GUARANTEES

Without prejudice to any applicable mandatory legal guarantees, Panaget shall contractually guarantee the design quality of its wood flooring and wall panelling for 30 years in line with normal usage. The duration of the guarantee shall be mentioned on each Good and shall apply as from resale to the users.

However, Panaget shall not apply the guarantee to:

- downgraded or clearance Goods;
- goods not paid for in full;
- apparent defects not notified before or during the laying of the relevant Goods;
- damage that is deliberate or caused by fair wear and tear, negligence, incorrect storage, an accidental act, an unplanned event or a case of force majeure;
- goods not laid, used or stored in compliance with the recommendations contained in the corresponding User Guide or printed on the packaging or in our technical list;
- maintenance not in accordance with Panaget recommendations
- a difference in appearance compared with that of samples which have not undergone the same exposure to UV radiation (patina);
- laying in rooms where water is in regular use (bathrooms, kitchens, etc.) unless the block flooring is designed specifically for this purpose;
- if the product is installed in locations subject to significant changes in humidity, such as saunas, steam rooms and swimming pools;
- faults related to failure to comply with the climatic conditions laid down and which would have been avoided if the humidity of the air had been regulated by the use of a humidifier or a dehumidifier and appropriate ventilation;
- cases where the Client or the user has personally repaired defective Goods or has had them repaired by a third party (other than minor repairs for maintenance purposes);
- wear due to penetration (stiletto heels, etc.) of the wood and damage to the finish (lacquer, oil, colour, etc.) related to the use of the room.

Furthermore, any applicable guarantee is limited to replacing defective Goods by supplying identical or similar goods and excludes the costs of lifting a laid floor, laying another floor and any compensation.

11 - PRICES

Goods will be billed at the prices extant on the date the relevant order was made.

Goods produced to a specification are always sold and billed against the quotation, which is issued for a term of two months

Carriage will either be paid by Panaget or billed as an extra, under the conditions laid down and at the price current on the day of the corresponding order by the Incoterm agreed between the Parties.

Unless specified differently, charges, taxes and any excise duties due shall be paid by the Client.

12 - PAYMENT - PROCEDURES

12.1. As regards national sales, Goods are to be paid for in Euros at Panaget's registered office by cheque, bank transfer or commercial paper:

- cash for any initial order;

- within 30 days of the invoice date for subsequent orders providing there is credit insurance.

If payment is made by bill of exchange against a statement of account, the Client must return the accepted bill within 8 days. We do not grant discounts for early payments.

12.2. Concerning international sales, unless agreed differently, payment shall be made in cash on delivery in Euros, by SWIFT bank transfer or even, at Panaget's simple request at the time of accepting the order, by letter of credit under the conditions specified by the latter. We do not grant discounts for early payments.

12.3. In any event, if there is a risk of the Client becoming insolvent or if there will be collection issues, and/or for any other similar reason, Panaget may demand any guarantee, a deposit, a reduced payment period and/or a payment in cash before executing orders.

Payment shall be deemed made on provision of the funds to Panaget, i.e. on the day that the amount is credited as cleared funds to one of the latter's bank accounts.

13 - PAYMENT: LATE PAYMENT OR DEFAULT

Late payments will be subject to penalty interest at the European Central Bank rate plus 10 basis points from the due date until payment is made, in accordance with article L441-6 of the French commercial code.

Furthermore, any delay in payment will entail de jure suspension of the performance of any outstanding orders, removal by way of a penalty of the Client's rights to any price reduction and the immediate calling in of any debt owed to Panaget.

If you fail to make payment within 15 calendar days of being sent a first reminder, we may cancel your order, and any other unpaid orders and/or contracts, regardless of whether these have been or are being fulfilled, and of whether the payment is late. Panaget will then retain any deposits which may have been paid, without prejudice to any other compensation and any other costs.

Payment of the price shall be made on provision of the cleared funds to Panaget and will be made by the Client at Panaget's registered office or at the place nominated by the company.

You may not offset any amounts which we owe you against all or part of a payment to us. We may set a credit limit, or reduce your existing limit, or change our terms of payment, at any time.

The Client will have to refund any expenses incurred by failure to pay on the due date entailing a return of any bills of exchange, unpaid cheques, and by recovery of the sums owed, including fees for bailiffs and solicitors.

We may charge an automatic fixed penalty of 40 euros to cover our collection costs as specified in article L441-6 of the commercial code, and may also pass on any additional collection costs which we incur, subject to the provision of supporting documents.

14 - FORCE MAJEURE

























Cases of force majeure concerning Panaget's obligations are deemed those events over which it has no control and which it could not reasonably be expected to anticipate, insofar as their occurrence makes discharging its obligations more difficult or more burdensome. This shall also apply in all circumstances even if these are not covered by the aforementioned definition, in particular cases of war, explosion, acts of vandalism, riots, civil commotion, acts of terrorism, machine failure, fire, storm, water damage, strike, lock-out, acts by government, embargo, lack of raw materials, supply problems, changes to the regulations applicable to the Goods, occurring in Panaget's factories and/or premises and/or on the premises of suppliers and/or service providers used by the company.

15 - PERSONAL DATA

The Parties undertake to comply with the regulations relating to the collection and processing of personal data, including Regulation (EU) 2016/679 of the European Parliament and of the Council dated 27 April 2016 (the "GDPR"). As the data controller, Panaget processes its customers' data electronically to manage orders. Personal data collected in this context (customer's company name, first name and surname of the customer's contact person, email address, business telephone or fax number) is strictly necessary to fulfil the order, delivery, billing and collection. This data is kept during the commercial relationship and for the duration of the legal retention period. Recipients of the data include our customer services, sales, billing and collection departments, and our subcontractors responsible for delivery. Customers have the right to access, rectify, erase and object to the processing of their personal data by sending an email to dpo@panaget.com or by writing to PANAGET - Data Protection Officer - 3 Rue d'Orgères, 35230 Bourgbarré. Customers who feel that Panaget has failed to respect their rights and adequately address their complaints may complain to the French Data Protection Authority (Commission nationale de l'informatique et des libertés or CNIL).

Colour chart

TIMELESS NATURAL HUES

		BOIS FLOTTÉ	BOIS NATUREL OIL	SATIN	OPALE	TOPAZE	NATURAL OIL	MIEL	AMANDE	SABLE	
											
											
		Available in High Traffic Lacquer				Available in High Traffic Lacquer		Available in High Traffic Lacquer			
THE ESSENTIALS	CLASSIC (select)	Diva 139-12/14 Diva 184-12/14 Orféo 139-14		Diva 90-12 Diva 139-12/14 Diva 184-14 Orféo 139-14 Chevron 90 Carmen n°1, 2, 5	Diva 139-12/14	Diva 90-12 Diva 139-12/14 Diva 184-14 Orféo 139-14 Chevron 90 Sonate 140-14					
	AUTHENTIC (middle grade)	Diva 139-12/14 Diva 184-12/14/15 Diva 223-15 Chevron 90 Chevron 139 Herringbone 139	Diva 184-12	Herringbone 90 (mixed Cl/Auth) Sonate 90-14	Diva 184-12	Diva 139-12/14 Diva 184-12/14/15 Diva 223-15 Chevron 139 Herringbone 90 (mixed Cl/Auth) Herringbone 139 Sonate 90-14 Sonate 140-14	Sonate 90-14 Sonate 140-14	Diva 139-12/14 Diva 184-14		Diva 223-15 Chevron 139	
	ZENITUDE (rustic)	Diva 90-12 Diva 139-12/14 Diva 184-12/14 Herringbone 139 Sonate 90-14 Sonate 140-14	Diva 139-12 Diva 184-14					Diva 139-12/14 Diva 184-14	Diva 184-14 Chevron 139 Herringbone 139 Sonate 90-14 Sonate 140-14	Diva 139-12 Diva 184-14	Diva 139-12 Diva 184-12/14
	ZENITUDE-ORIGINE (aged bevels)										Diva 139-14 Diva 184-14
	ZENITUDE-SALVAGIO (structured, sometimes irregular facings)						Diva 139-14				
THE INDISPENSABLE	MIX	Alto 139*2010 Alto 184*2010 Single plank 139			Single plank 139	Alto 139*2010 Alto 184*2010 Single plank 139					
& ALSO AVAILABLE	TRADITION	Alto 139*1210		Alto 139*1210 Orféo 139-14		Alto 139*1210				Alto 139*1210	
	INTENSO	Diva 139-12 Diva 184-14									
FLAMED BEECH			BOIS FLOTTÉ			SATIN			NATURAL OIL		
All finishes are available in Diva 139/14 mm click. Bois flotté and Satin are also available in Herringbone 139.											

DAYLIGHT WHITES					SUBTLE GREYS				ELEGANT BROWNS				
SHABI CHAUX	SAPHIR	WHITE OIL	LINEN	TUFEAU	CAFÉ CRÈME	RAFIA	GREY OIL	FLANELLE	ARGILE	HABANO	CUIR	FAUVE	TOURBE
													
													
			Diva 90-12 Diva 139-14										
	Diva 139-14 Diva 184-14 Sonate 140-14		Diva 139-12 Herringbone 90 (mixed Cl/Auth)	Diva 139-14 Diva 184-15 Herringbone 90 (mixed Cl/Auth)	Diva 139-14 Chevron 139			Diva 184-15	Diva 223-15	Herringbone 90 (mixed Cl/Auth)	Diva 90-12 Diva 139-12/14 Diva 184-12/14/15 Sonate 140-14		
Alto 139*1210		Diva 139-12	Diva 139-12 Diva 184-12/14 Sonate 140-14	Diva 139-12 Diva 184-12/14 Chevron 90	Diva 139-12 Diva 184-14 Sonate 140-14	Diva 184-12/14	Diva 184-14	Diva 184-14	Diva 184-14	Diva 139-12		Diva 139-14 Diva 184-14	Diva 184-14
Herringbone 139				Diva 139-14 Diva 184-14 Herringbone 139				Herringbone 139			Diva 139-14 Diva 184-14 Sonate 140-14		Diva 184-14
							Diva 139-14						
			Single plank 139										
	Orféo 139-14				Alto 139*1210								
				Diva 139-12							Diva 139-12 Diva 184-14		
												CUIVRE	

imagine

by Panaget

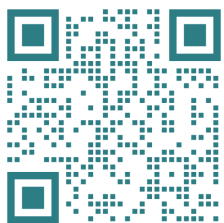

I try!

Panaget wood floor simulator, redecorate your home!

PANAGET

manufacture française de parquet
DEPUIS 1929



une société du **groupe Bouyer Leroux**

www.panaget.com

3, rue d'Orgères 35230 Bourgbarré - France

Tél. | 0033 2 99 05 77 77

Fax | 0033 2 99 57 73 55